

# Installation techniques and detailing

Self-coved with cove former and capping seal C11 over floor tiles

For locations where existing quarry tiles cove needs to be covered with sheet vinyl flooring. The Altro sheet flooring should be covered over a CF38R / CF20R radius cove former, fixed at the junction of the wall and floor, up to the top edge of the quarry tile cove and finished into the Capping Seal C11. The cove former, Altro flooring and C11 used in this section

must be adhered with a suitable contact adhesive. All mitres and joints within the coving must be hot welded. AltroMastic 100, colour black, should be applied to the junction between C11 and the wall surface.

**Drawing Ref: D6/03/05**

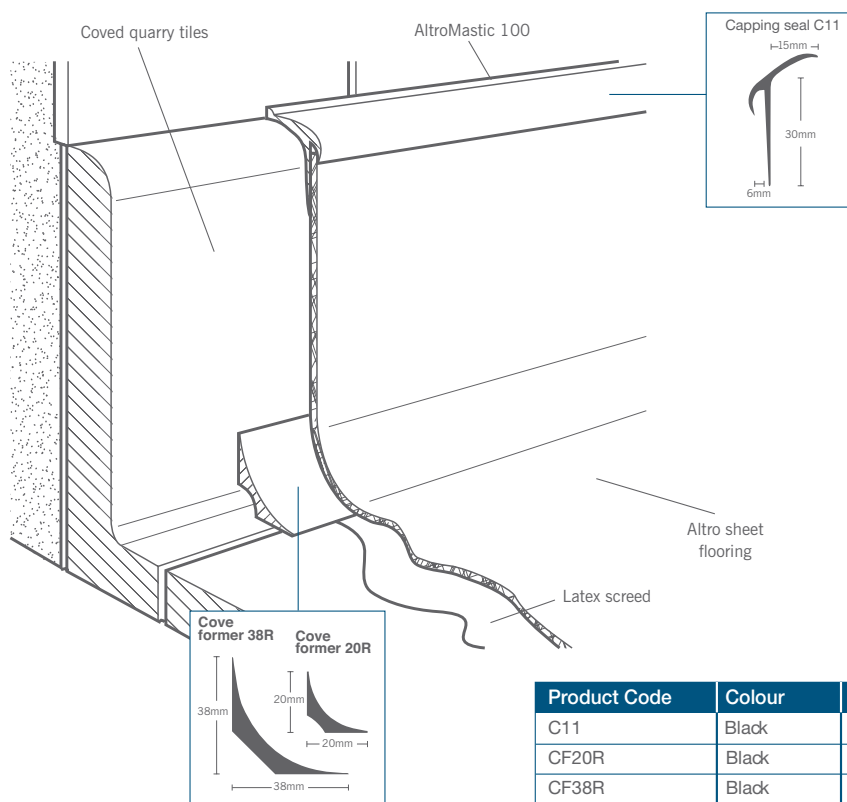

**For further information or technical advice**

**tel: 01462 707600**

**email: [enquiries@altro.com](mailto:enquiries@altro.com) or [www.altro.com](http://www.altro.com)**