



altro

# Commercial kitchen and back-of-house areas

An introduction to using Altro floors + walls in commercial kitchen and back-of-house areas

discover [altro.com/kitchens](https://altro.com/kitchens)



Our story begins in 1919 when a small group of individuals had an idea...

That idea has grown into a global company with over 900 employees and one idea has become many. From inventing safety flooring and developing an integrated hygienic walls system to creating the world's first adhesive-free safety floor.

While the world in 1919 couldn't seem more different from today's our excitement at embracing and developing new technologies and ways of working with our customers is exactly the same as back then.

Add to this, we remain a family business, with family values and I think you have the reason why we're here today, over 100 years later.

our history

To work across multiple sectors requires real-world understanding.

The ability to design for a purpose and address the challenges, issues and regulations for each industry without ever compromising on quality or safety.

We work in the following sectors including niche areas within these sectors;

Healthcare

Hospitality

Transport

Education

Housing

Food + drink production

Leisure

Retail + offices

Prisons + defense

Manufacturing + warehousing

our expertise

Only Altro has over 60 years' experience in delivering floors and walls for commercial kitchen and back-of-house areas

We have specifically designed our system to address issues commonly found in these areas

- ✓ Safety
- ✓ Hygiene
- ✓ Cleanability
- ✓ Durability

- Restaurants
- Bakeries
- Bars
- Commissaries
- Central kitchens
- Food manufacturing
- Food courts
- Grocery stores
- Service corridors

Common kitchen contaminants can spell danger in any fast-moving food preparation and cooking area.

Risk of slips	Altro R12 (Altro Stronghold 30)	Altro R11 (Altro Classic 25)	Altro R10 (Altro Atlas 40)
Water	1 in a million	1 in a million	1 in a million
Vegetable oil	1 in a million	1 in 100,000	1 in 20
Greasy water	1 in a million	1 in 100,000	1 in 20
Milk	1 in a million	1 in a million	1 in a million
Flour	1 in a million	1 in a million	1 in a million
Plastic wrapping	1 in a million	1 in a million	1 in a million

staying safe



Keeping people safe isn't just about slip resistance and cleaning. It's about preventing contamination.

- ✓ HACCP International approved
- ✓ USDA, FDA, CFIA compliant
- ✓ Integrated floor + wall system for full coverage
- ✓ Durable and high-impact resistance
- ✓ Easy-to-clean, tankable, able to be power washed
- ✓ Non-absorbent, non-porous, non-fibrous, non-shedding
- ✓ Impermeable surfaces, resists growth of bacteria

keep it clean

# Choosing Altro for your next kitchen and back-of-house installation has it's benefits

- ✓ Permanent, consistent slip resistance
- ✓ Welded seams for superior hygiene
- ✓ Proven 10x less bacteria than quarry tile (Halo test)
- ✓ No broken tiles or cracking, no epoxy or regrouting needed
- ✓ Better underfoot comfort
- ✓ Installs faster than tile or epoxy for less kitchen downtime
- ✓ Can be installed over approved existing substrates
- ✓ Longer warranties
- ✓ Altro Puraguard wall protection is 3x more impact-resistant than FRP
- ✓ Altro wall panels are non-shedding

why Altro?

Kitchens and wet areas  
installers. The difference  
bad installation is usual

That's why we have developed an entire  
system. Complete with accessories like  
diagrams, CAD files, and in-depth insta

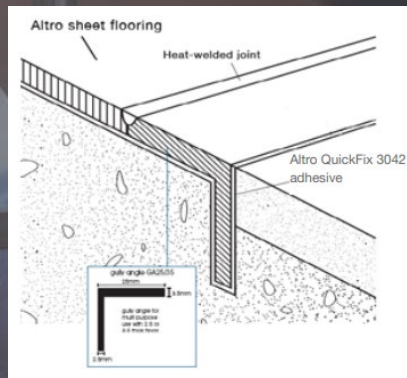
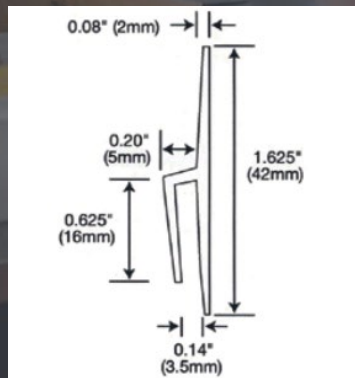
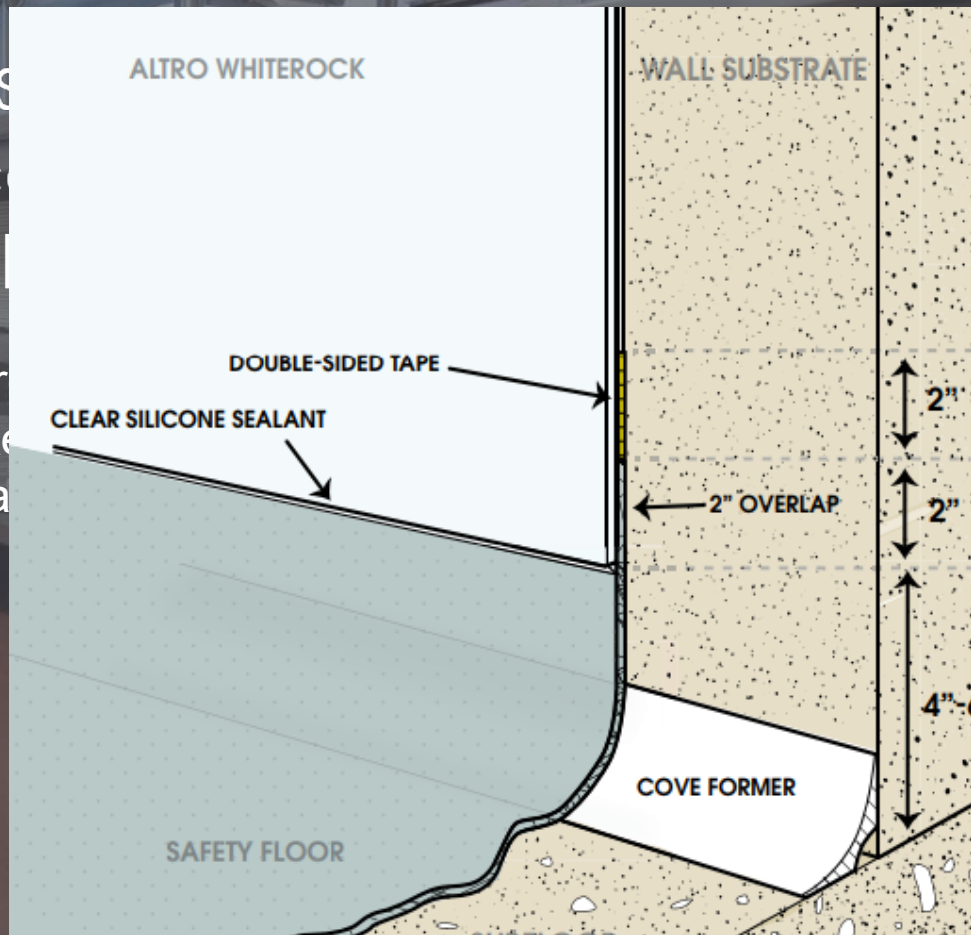

See our resources online or ask your representative



before



after







# Altro Stronghold 30

*Safety flooring – homogeneous sheet*

Altro Stronghold 30 achieves Altro's highest slip resistance rating and is designed to minimize risk in wet and greasy conditions for the lifetime of the floor.

<b>Thickness</b>	3.0mm
<b>Dimensions</b>	6'7" x 49' (2m x 15m)
<b>Static load</b>	2000psi
<b>Sound insulation</b>	10dB
<b>Warranty</b>	12 years

## Slip-resistance

SCOF	.92 Dry / .88 Wet
DCOF	.74 Wet
Ramp test	R12
Pendulum test	55+

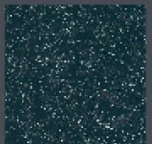
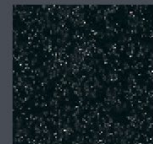
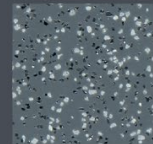
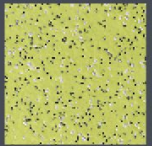
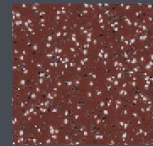
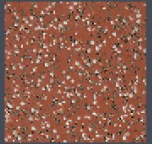
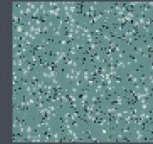
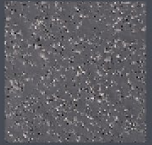
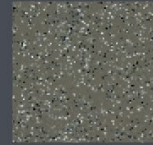

# Altro Classic 25

*Safety flooring – homogeneous sheet*

Classic by name, classic by nature, Altro Classic 25 was the first ever safety flooring; it has been tried and trusted for over 60 years, and its traditional look is still popular today.

<b>Thickness</b>	2.5mm
<b>Dimensions</b>	6'7" x 65' 5" (2m x 20m)
<b>Static load</b>	1000psi
<b>Sound insulation</b>	5dB
<b>Warranty</b>	12 years

## Slip-resistance

SCOF	.9 Dry / 1.0 Wet
DCOF	.60 Wet
Ramp test	R11
Pendulum test	45+



# Altro Atlas 40

*Safety flooring – homogeneous sheet*

Altro Atlas 40 is our most robust safety flooring, maintaining its integrity even when superficially punctured. It's well suited to heavy industrial use like 24/7 kitchens and food manufacturing.

<b>Thickness</b>	4.0mm
<b>Dimensions</b>	6'7" x 41' (2m x 12.5m)
<b>Static load</b>	500psi
<b>Sound insulation</b>	7dB
<b>Warranty</b>	15 years

## Slip-resistance

SCOF	.70 Dry / .70 Wet
DCOF	.57 Wet
Ramp test	R10
Pendulum test	36+

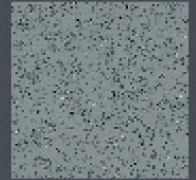
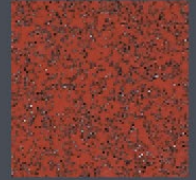
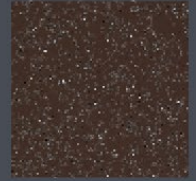

# Altro Puraguard

*Wall protection system*

Create a complete kitchen solution by adding Altro Puraguard to Altro safety flooring. The easy maintenance, hygienic PVC surface will help you assure your kitchen is clean and food is safe for consumption. Altro Puraguard is the better alternative to FRP.

<b>Thickness</b>	2.5mm
<b>Dimensions</b>	4' x 9' (1.22m x 2.74m) and 4' x 10' (1.22m x 3.04m)
<b>Impact resistance</b>	Exceeds 64 inch pounds of force
<b>Warranty</b>	2 years







**Stainless steel**

Placed behind cooking lines and under high heat equipment.

# Industry leading cleanability while maintaining slip resistance with Altro EasyClean

- ✓ Not a surface finish – incorporated into product during manufacturing for long-term cleanability.
- ✓ Low dirt pick-up
- ✓ Improved color retention
- ✓ Cleaning instructions available online and in print
- ✓ Cleaning supplies, including cleansers, formulated to work exceptionally well with Altro products



cleaning

# The correct installation and detailing is of the utmost importance in every environment. We pride ourselves in our technical offerings.

## Install guides



## Detailing guides



## Drawings / CAD

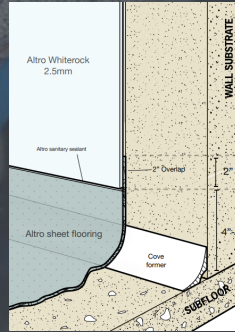

## Accessories



## Technical services



# installation

# better together

In areas of frequent spills, hygiene and durability concerns, it's best to let our robust collection of safety flooring and wall protection take the lead.

Install smooth flooring in the dining room and public areas, and bring slip-resistant flooring into the restrooms and behind the bar.

Rest easy knowing your patrons will have an exquisite experience while your most dangerous areas are well equipped to handle the tolls of the day.



We are here to support you with all your commercial flooring and wall cladding needs.

Samples + literature

Specifier resources

CEUs + Installer training

Customer care

800.377.5597  
support@altrofloors.com

Submit an online request!

## Commercial kitchens learning library contact form

### Please send me more information!

- Send me a free sample set
- Send me some free literature
- I'm interested in booking a CEU for AIA / IIDA credits (in-person or digital)
- I'm interested in my local Altro representative reaching out via phone or email

### Name

First Name Last Name

### Company

### Address

Street Address

Street Address Line 2

City State / Province

Postal / Zip Code

### Email



altro

Discover more in-depth knowledge on this sector and represented products on our website.

Be sure to explore our full digital learning library for more mini-course like this.



discover [altro.com/kitchens](https://altro.com/kitchens)