

altro



Fitting guide

Altro PVCu wall system

Altro wall system fitting guide

This fitting guide, whilst compiled to the best of our knowledge is for guidance only, and Altro cannot be held responsible for any faults which may occur. If in any doubt, contact the technical services department to answer any queries you may have. Tel: 01462 707600.

Altro Whiterock semi rigid extruded PVCu wall sheet can be used in hygienic environments and areas subject to wet usage. The walling system has excellent adhesion properties to all sound substrates used for internal wall construction. It is suitable for new and refurbishment building projects. A range of sheets are available in White, Satins, Decorative, High Gloss finish and the bespoke Altro Digiclad (Custom) range.

Altro Fortis Titanium semi rigid extruded PVCu wall sheet can be used in busy public areas subject to impact and scuff damage. The walling system has excellent adhesion properties to all sound substrates used for internal wall construction. It is suitable for new and refurbishment building projects.

The walling systems incorporate a range of colour coordinated jointing systems, including two part joint trims, flexijoint, welded and single part trims for use in secure environments.

AltroFix adhesives are supplied to fix all types of sheet.

Altro sanitary sealant are food-safe and available in co-ordinating colours.

Altro wall products:

Altro Whiterock Digiclad (Custom) - Custom print option utilising UV cured inks onto an Altro Whiterock sheet from a design or photographic image.

Altro Whiterock Whiteboard - Wall mounted note board to capture non-permanent ideas. Dry wipe clean for repeated use.

Altro Whiterock Imagination Wall - 2.5mm thick PVCu panels with preprinted designs for colouring in by children.

Altro Whiterock wall designs - Altro Whiterock wall sheet in a range of natural wood, metal, stone and linen designs

Altro Whiterock Satins - 2.5mm PVCu sheet in a colourful, satin finish.

Altro Whiterock Chameleon - High gloss 2.5mm PVCu sheet for high-end public areas, durable and hygienic.

Altro Whiterock recessed shelf - An integrated shower shelf insert to match Altro Whiterock wall sheets.

Altro Tegulis - Tile-effect wall panels with innovative etched grout lines.

Altro Fortis Titanium - 2.5mm PVCu textured sheet providing durable protection for walls, doors and corners.

Altro Fortis corner protection - Ready-made piece for added protection along the wall's vulnerable corner.

Altro Walls ShowerKit - A pre-packaged Altro Whiterock wall cladding system for shower, bath and ensuite.

Altro Whiterock White - Impact-resistant, impermeable, grout-free, easy maintenance 2.5mm PVCu sheet which is a hygienic alternative to ceramic tiles.

Altro Whiterock Splashbacks - Pre-cut or custom-sized hygienic alternative to tiles made from Altro Whiterock Satins or Altro Whiterock Chameleon sheets.

Altro Whiterock Hygienic doorsets - Fully encapsulated hygienic integrated doorset made with Altro Whiterock PVCu sheet (FD30 & FD60).

Altro Fortis doorsets - Fully encapsulated integrated doorset made with Altro Fortis Titanium sheet (FD30 & FD60).

Description

Sheets are available in a variety of sizes. Please refer to product data sheets for sizes. Altro Whiterock Digiclad (Custom) sheets are trimmed prior to preparation of pattern application.

The sheets are supplied with a protective film on the face which can be left in place until the area is ready for use. This also helps protect the new surface from dust while other trades are working in the area.

Altro PVCu wall sheets have a maximum working temperature of 60°C.

For areas that exceed these maximum temperatures, such as direct heat sources or where there is exposure to naked flames (examples being air fryers, heat vents, cookers, oven ranges, wall-mounted griddles etc.) it is recommended that stainless-steel sheets are used. Where installations of stainless-steel sheets are to be included, the stainless steel must extend at least 300mm beyond the heat source to ensure protection of these localised areas is maintained.

If a layout drawing highlighting areas where heat may be of concern can be provided, specific advice can be provided as to the best combination of materials to use.

On delivery, sheets should be checked for any possible faults prior to installation.

Claims against guarantee for colour, batch or obvious material defects will only be considered if the wall sheets have not yet been installed.

Ensure that the material used in any one area is from the same manufacturing batch, and on large projects where multiple sheets are used, it is best practice to use sheets off of one pallet before moving on to the next numbered pallet.

Surface preparation

All surfaces must be smooth, sound, dry and free of contamination. If necessary, the walls should be cleaned down prior to the Altro wall sheet installation, and primed using 10 parts water to 1 part PVA. - do not use Altro W165.

The working environment must also be clean and dust free. Failure to comply with these conditions will reduce the bond strength between adhesive and substrate, and may cause the sheets to de-bond.

- All substrates to be dry to 16% WME (Wood Moisture Equivalent) on Protimeter 'Surveymaster' equipment.
- All loose flaking paint and dust to be removed.
- Friable surfaces to be removed or made sound using proprietary surface treatment as advised by Altro.
- All surfaces to be free from grease. Ceramic tiles must be securely bonded to the substrate, thoroughly cleaned and degreased using a suitable degreasing agent and scouring pad, fully rinsed with clean water and allowed to dry. Abrade the surface with a diamond abrasive disc to scratch through the tile glaze and remove all dust. Tiles should be rinsed for a second time and allowed to dry. Use a grinder or sanding equipment fitted with a captive dust bag or vacuum.
- Loose tiles to be removed and the area made good using Ardurapide 45 rapid repair mortar, sand and cement with Unibond mix (if drying time permits), render coat or a comparable thickness plywood infill.
- Depressions in the substrate should be filled with Ardurapide 45 rapid repair mortar, sand and cement with Unibond mix, or render coat if drying time permits.
- All electrical switches, power points etc should be in a first fix state where possible. All electrical equipment should only be moved or altered by a qualified electrician.
- If possible, plumbing and pipework should be removed to be at first fix state and "tails" left protruding from the substrate. Sheets can then be drilled and slid over the pipe "tails". All holes should be drilled 3mm oversize to allow for expansion. Plumbing should always be carried out by a qualified plumber.
- Hot pipes and steam pipes should be insulated and a 3-5mm expansion gap should be created when installing sheets around these pipes.
- All pipes, screw fixings, bolts etc: fixed through the sheet should have minimum 3mm expansion gaps and be sealed using Altro sanitary sealant.

AltroFix W139

The sheets can be fixed directly to most sound and dry substrates with AltroFix W139, two-part polyurethane adhesive.

The adhesive is available in two tub sizes:-

- 6.5kg unit (ref: A814/25) for 2100 and 2500mm sheets
- 8.0kg unit (ref: A814/30) for 2750 and 3000mm sheets

Part A is a viscous cream coloured paste supplied in a plastic tub. Part B is a catalyst (hardener) supplied in a foil bag (separated within the tub).

Pour the liquid contents of the foil bag (Part B) into the plastic container holding Part A and mix thoroughly for approximately 2-3 minutes until a uniform consistency is obtained throughout.

A low speed electric drill with mixing paddle attachment should be used to ensure complete mixing.

Once mixed, the adhesive should be applied to the (pre-cleaned) back of the sheet with a 5mm x 5mm square notched trowel.

Health and Safety Advice

Before using this adhesive, users must refer to the SDS (Safety Data Sheet) for correct safety advice and carry out a COSHH (Control of Substances Hazardous to Health) assessment and risk assessment.

Always wear appropriate PPE (Personal Protective Equipment) and RPE (Respiratory Protective Equipment) when handling adhesives and ensure the area is adequately ventilated.

In the case of contact with eyes or skin, rinse immediately with plenty of water and seek medical advice.

Product for professional use

As from 24 August 2023 adequate training is required before industrial or professional use.

AltroFix W157

The sheets can be fixed to most smooth, sound, dry and porous substrates with AltroFix W157 single part Acrylic water based synthetic polymer emulsion adhesive.

The adhesive is available in three tub sizes:

- 3kg unit (ref: A818/03) for 2500mm sheets
- 4kg unit (ref: A818/04) for 3000mm sheets
- 12kg unit (ref: A818/12) for 2500mm / 3000mm sheets

A low speed electric drill with mixing paddle attachment should be used to ensure the adhesive has a smooth creamy consistency for easier troweling.

Once mixed, the adhesive should be applied to the (pre-cleaned) back of the sheet with a 3mm x 3mm square notched trowel.

Note: AltroFix W157 is not suitable for fixing to non-porous substrates or for use in wet environments such as showers and wet rooms.

Health and Safety Advice

Before using this adhesive, users must refer to the SDS (Safety Data Sheet) for correct safety advice and carry out a COSHH (Control of Substances Hazardous to Health) assessment and risk assessment.

Always wear appropriate PPE (Personal Protective Equipment) and RPE (Respiratory Protective Equipment) when handling adhesives and ensure the area is adequately ventilated.

In the case of contact with eyes or skin, rinse immediately with plenty of water and seek medical advice.

AltroFix W639

The sheets can be fixed directly to most sound and dry substrates with AltroFix W639, two-part MS Polymer adhesive.

The adhesive is available in one size:-

- 5.0kg unit (ref: A639/5KG) for all sheet sizes

Part A is a viscous cream coloured paste supplied in a metal pail. Part B is a blue coloured catalyst (hardener) supplied in a foil bag (separated within the tub).

Pour the liquid contents of the foil bag (Part B) into the metal container holding Part A and mix thoroughly for a minimum 3 minutes until a uniform consistency and colour is obtained throughout.

A low speed electric drill with mixing paddle attachment should be used to ensure complete mixing. Scrape the sides thoroughly during this process. Care should be taken to avoid spillage when mixing, as staining of floor coverings may occur.

Once mixed, the adhesive should be applied to the (pre-cleaned) back of the sheet with a 4mm x 4mm square notched trowel.

Health and Safety Advice

Before using this adhesive, users must refer to the SDS (Safety Data Sheet) for correct safety advice and carry out a COSHH (Control of Substances Hazardous to Health) assessment and risk assessment.

Always wear appropriate PPE (Personal Protective Equipment) and RPE (Respiratory Protective Equipment) when handling adhesives and ensure the area is adequately ventilated.

In the case of contact with eyes or skin, rinse immediately with plenty of water and seek medical advice.

Suitable fixing methods

Substrate	AltroFix W139	AltroFix W157	AltroFix W639
Gypsum Board 12.5mm (e)	*	*	*
Minimum 9mm WBP Plywood*	*	*	*
Metal	*		*
Ceramic Tiles (a)	*		*
Plaster (b)	*	*	*
Cement Render (b)	*	*	*
Brickwork (b & c)	*		*
Blockwork (b & c)	*		*
Painted (d)	*		*
Water resistant cement based board (e)	*		*

(a) = Provided tiles are firmly bonded to the substrate and free from surface contamination, grease etc:

(b) = Surface should be dry. If in doubt test with a Protimeter, which should give a maximum reading of 16% wood moisture equivalent (WME). Plastered surfaces must be sealed with diluted PVA (or similar) before installation of the Altro wall sheet.

(c) = Brickwork and Blockwork should be of good quality and joints should be flush and dry.

(d) = A bond test is advisable to check adhesive does not react with paint.

(e) = AltroFix W157 should not be used for bonding to moisture resistant substrates

* = Plywood must comply to EN 13986: 2004
 BS EN 636: 2003
 BS EN 315
 BS EN 314-2

Glue bond quality class 3 's' grade

Please ensure you follow the installation guidelines carefully to ensure best results.

Suitable substrates

- Good quality fair-faced brick or blockwork with well aligned joints all bagged up flush and all cement spots removed. Surfaces should be true and level to +/- 3mm over a 2m straight edge and brick / blocks flush with those adjacent. Not a suitable substrate for welding, please contact Altro for advice.
- Sand and cement rendering 1:3 mix with a steel trowelled finish.
- 12.5mm thick plasterboard.
- Minimum 9mm see specification details resin bonded plywood.
- Minimum 9mm MDF dense wood based moisture resistant sheets.
- 12mm plywood when applied to studwork at max 450mm centres.
- Ceramic tiles which must be securely bonded to the substrate, thoroughly cleaned and degreased using a suitable degreasing agent and scouring pad, fully rinsed with clean water and allowed to dry. Abrade the surface with a diamond abrasive disc to scratch through the tile glaze and remove all dust. Tiles should be rinsed for a second time and allowed to dry. Use a grinder or sanding equipment fitted with a captive dust bag or vacuum.
- Most sound painted surfaces (an adhesive test is advisable to ascertain suitability).
- New pink finishing plasters. These surfaces are generally dusty. They should be brushed and thoroughly sealed with diluted PVA primer (1:10), or Altro Consolidating Primer dry to 16% WME.

Installation temperatures

Altro recommends the PVCu wall sheets are installed at approximately the same ambient 'service temperature' at which the area will be used when commissioned.

A minimum temperature of 14°C/57°F is recommended for all installation areas.

AltroFix adhesive must never be used below +5°C.

Sheets should be stored flat and be pre-conditioned for up to 24 hours to attain the ambient room temperature prior to the installation.

The sheets must be stored on a level flat surface off the ground (risk of condensation on the sheets if stored on damp surfaces).

Storage on un-even surfaces could cause the sheets to distort prior to installation.

Tools and equipment

In general, the main tools required are similar to carpentry hand tools. Below is a list of tools that you may find an advantage to have for the installation.

- 1 metre & 2 metre spirit levels
- stanley knife
- square
- chalk line
- laser level
- adjustable block plane
- 5m tape measure
- hammer
- carpenters bevel
- cold chisel
- rubber mallet
- carpenters 19/25mm wood chisels
- screwdrivers
- files (round & square)
- hole cutters
- hacksaw
- sharpening stone
- Scrapers
- metal snips
- 50mm paint brush
- good quality mastic gun
- mixing paddle
- 5mm x 5mm square notch steel trowel
- biro pens and pencils
- water based markers
- hand roller
- 3000mm rigid straight edge
- electric Jigsaw (with 'fine tooth' cutting blades)
- plunge saw with T.C.T blade and pressure guide for cutting
- 750 watt electric drill (for mixing adhesive)
- if required (on site) - 110 transformer (including 110v leads)

Ensure all electrical equipment is PAT tested.

Safety equipment:

- barrier cream
- goggles / safety glasses
- protective gloves
- face mask (nose / mouth protection)
- hard hat
- safety boots
- hi-viz safety vest

Other essential equipment:

You will also need a 2.5 x 1.22m workbench made from 15mm MDF board (or similar), with support bearers to prevent the MDF from bowing in the middle. The bench provides an excellent work surface for the sheets which are 1.220m x 3.000m.

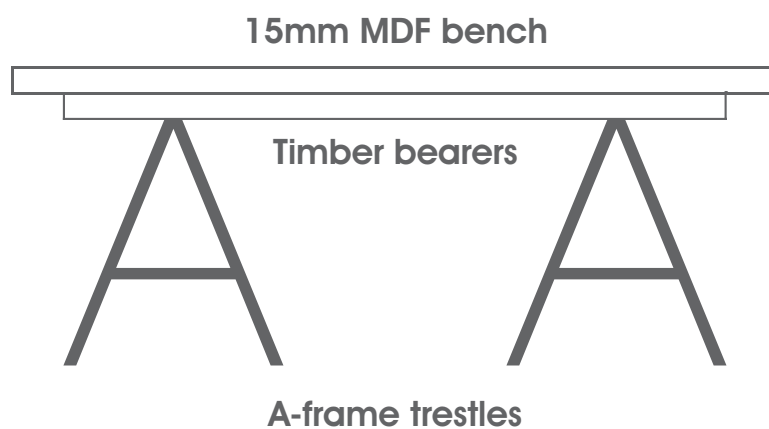

Safety information

Apart from the normal health and safety rules employed within the construction industry, the following points should be noted:-

- Safety information displayed on the tubs and containers supplied by Altro must be strictly adhered to.
- If AltroFix W139 is being used, prior to use, installers must have carried out training on the Safe Use and Handling of Diisocyanates.
- Safety eye wear must be worn during cutting of materials, mixing of adhesive, cleaning and preparation of site, and where necessary to adhere to site regulations.
- Use face masks
- Display prominent safety signs when using hazardous materials, and to warn of a working area.
- Ensure good ventilation within the work area.
- Remove and dispose of all waste sensibly and carefully as per site instructions. Contact Altro on 01462 707600 for all SDS (Safety Data Sheets).
- Apply barrier creams, and wear protective gloves when mixing and applying AltroFix adhesives. Long sleeves and trousers must be worn to protect skin.
- Keep the working area clean and tidy.

Before starting work, users must refer to the relevant SDS (Safety Data Sheets for correct safety advice and carry out COSHH (Control of Substances Hazardous to Health) assessments where necessary. Contact Altro on 01462 707600 for further advice.

Workstation

Set up a 'workstation' in close proximity to the area to be clad. A minimum area of 4m x 3m will be required to set up your work bench area.

Adjacent to the workstation, set up a 'glue-station', where all the mixing of adhesive takes place. The floor area in this location needs to be protected with cardboard (or similar) to prevent splashes of adhesive getting onto the floor.

If an existing or new floor has been laid prior to the installation of the wall sheets, it is essential to protect the floor around the work bench and the 'glue-station' where adhesive may get spilt.

The 'glue-station' is also where the trowels and mixing paddles are cleaned regularly to prevent a build up of excessive adhesive on the tools.

Please note: If the adhesive gets on the floor and is allowed to set, removal can be difficult, if not impossible. Therefore if a spillage or splashes occur, they should be wiped up immediately.

Setting out

- Firstly, check out the room which is to be clad, paying particular attention to the corners, window reveals, and door entrances. These need to be inspected to ensure they are straight, and free of any building waste which could prevent the sheets laying flat to the substrate after the adhesive has been applied and the sheet is installed.
- The wall surface must be clean prior to installation (if necessary, contact Altro Technical for specific recommendations on cleaning and preparation).
- Once preparation has been completed a datum line must be installed. The datum line is used for the calculation of measurements to ceiling height, sockets and pipes etc: and to ensure the sheets are 'plum' as the installation proceeds.
- The datum line should be installed at approximately 'eye level' on the wall and should be done with a laser for accuracy.
- The datum line height (from subfloor) should be calculated to allow for the appropriate skirting height where the bottom of the PVCu sheet meets the specific floor finish (sheet pvc flooring, quarry tiles, pvc sit-on skirting etc). **Note:** Quarry tile coving must always be installed before the wall sheet is fitted.
- A series of 'check measurements' should be taken around the room from datum to subfloor to ascertain the 'average' height of the datum line.
- The datum height (minus the appropriate floor skirting height) will eventually be transferred on to the face of the PVCu wall sheet. This will enable all subsequent measurements to be processed from the datum line on the sheet.
- Once all measurements have been taken from the wall, they can then be transferred on to the sheet. When the sheet is eventually fitted to the wall, the datum line on the sheet must line up with the datum line on the wall.
- After installing the datum line and calculating the average height, you must then plan the 'layout' of the PVCu sheets. This ensures the best layout of the sheets and minimises the number of joints used in the system.
- If hidden transition detail to be used apply to substrate prior to application of sheets.

Please ensure you follow the installation guidelines carefully to ensure best results.

Altro double sided tape primer application (REF: W165)

- Prior to the installation of Altro wall sheets, Altro W165 'tape primer' should be applied in three locations to the substrate with a 50mm paint brush. The primer 'lines' should correspond to the double sided tapes which will subsequently be fitted on the reverse side of the sheet - at the top, the middle (normally just below datum height) and at the bottom of the sheet. The double sided tapes hold the sheet firmly to the substrate whilst the AltroFix adhesive cures. Allow the 'tape primer' to dry to a tacky finish, (approximately 10 minutes). **Note:** The tape primer remains permanently tacky and never dries out totally.
- Before priming, the type of floor finish must be taken into account. With a sheet vinyl floor finish incorporating a self-coved skirting, the 'tape primer' (and subsequent double sided tape) must be applied high enough (i.e. min 20mm) to allow for a PVCu 'transition strip' to be fitted at the bottom of the sheet*. In the case of the sheet overlapping a sheet vinyl floor skirting (such as shower areas) where the vinyl has been installed first, a minimum height of 50mm from the bottom of the sheet is required. See diagram showing the double sided tape layout on the back of the sheet.
- When using two-part (snap-on) internal / external corner profiles, prime the wall corners with Altro W165 'tape primer' sufficiently enough to cover the area that the corners are to be installed. This should be done at the same time as the priming out for the double sided tape, allowing primer to dry to provide a tacky surface.
- When the walls are ready for application, double sided tape should be applied to the back of the PVCu corners in four strips of approximately 150mm long down the corner length. Remove the protective cover from the tape and apply the corner to the substrate.
- If a PVCu 'transition strip' is to be fitted (at a later stage) to the bottom of the sheet (where wall sheets meet the sheet vinyl floor skirting), the corner profile 'back section' must be fitted 20mm shorter than the overall length.
- **Never use Altro W165 as a full cover primer.**

*** Note: The transition trim A832 should never be used in wet areas such as showers and wet room adaptations.**

Altro double sided tape positioning (REF: A815) - Altro Fortis Titanium

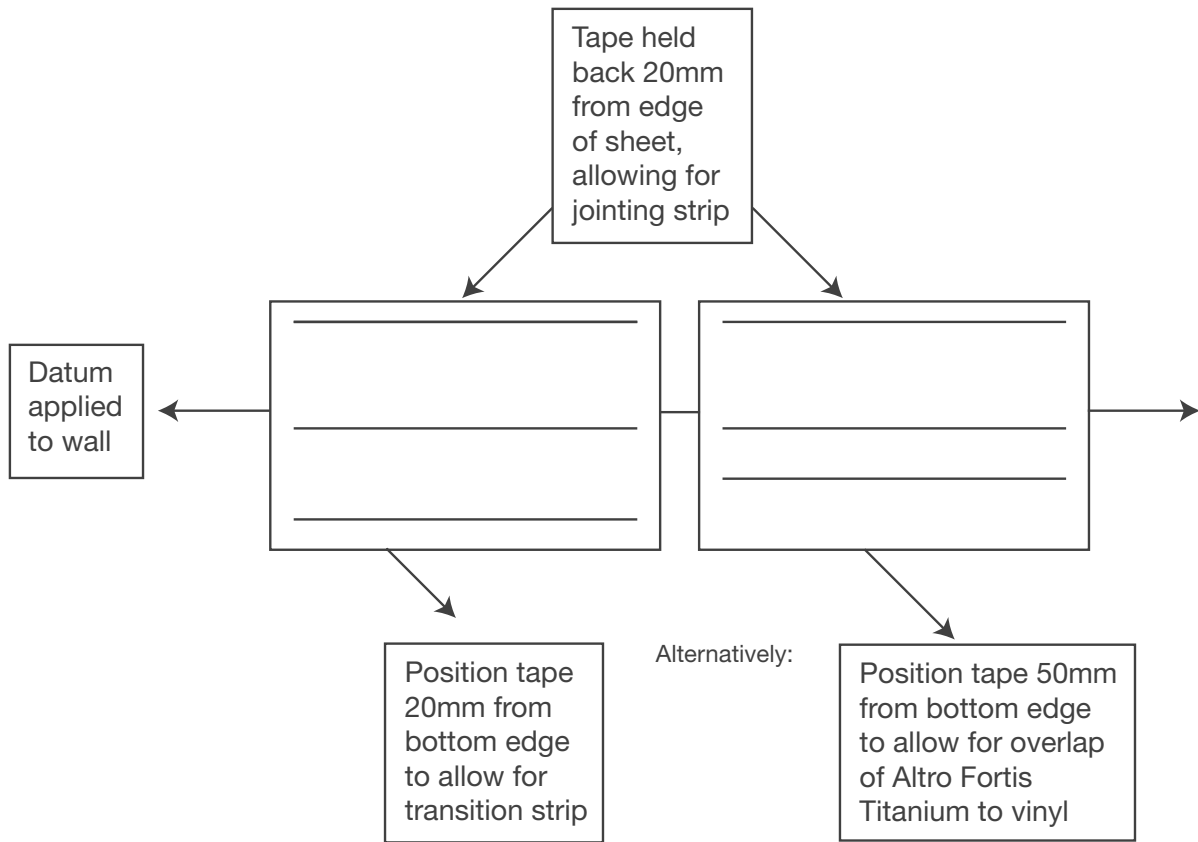

Please ensure you follow the installation guidelines carefully to ensure best results.

Altro double sided tape positioning (REF: A815) - Altro Whiterock

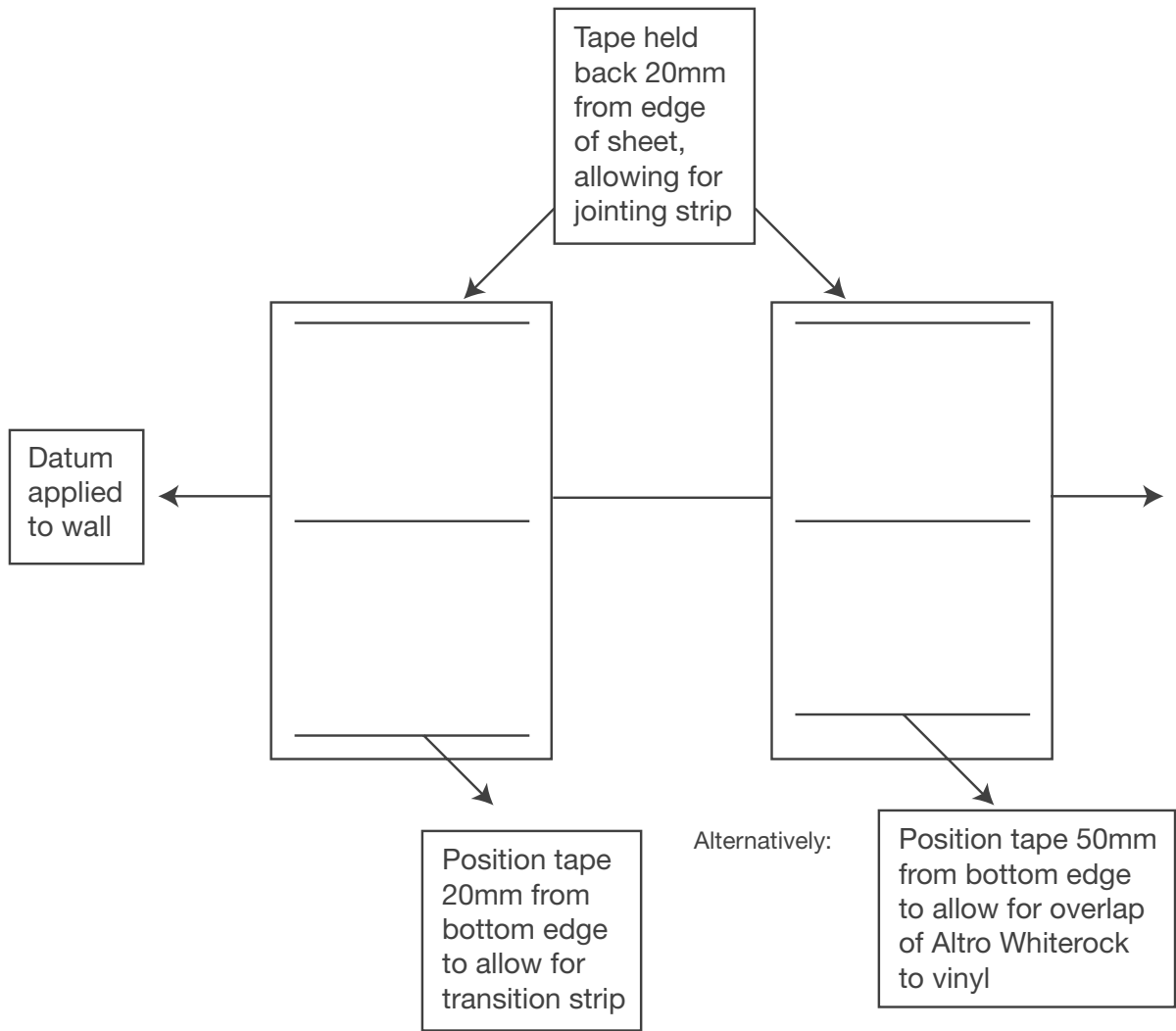

Installation procedure

Once all preparation has been carried out, walls are cleaned and free from dust, any possible contamination from grease (in kitchen and shower areas) has been removed, the datum line and 'tape primer' (Altro W165) have been applied, you are now ready to install the Altro PVCu wall sheets.

- Place sheet on the workbench and inspect for any damage. Carefully, on the front face (with the protective film), mark your datum with a biro pen, taking care not to press too hard, thus damaging the surface of the sheet.
- Take measurements from the wall, and then transfer these to the sheet. Cut the sheet making sure the sheet is well supported to reduce any risk of stress in the material when being cut.
- After the final cutting, plane the edges with your adjustable block plane to remove burrs and to leave a clean smooth finish.
- Offer the sheet to the substrate to check your work (dry fitting), ensuring you have a 2-3mm expansion joint at all abutments and pipe work.
- When the sheet has finally been made to suit the required wall finish detail, lay this face-down on the workbench and clean the back of the sheet.
- Apply double sided tapes at the top, middle and bottom of the sheet - to correspond with the Altro W165 primer (DO NOT remove the tapes' protective paper at this time).

Applying AltroFix adhesive

- Wear appropriate safety equipment before handling materials.
- For two-part Altrofix adhesives carefully mix parts A and B together using a large mixing drill and paddle for a minimum of 3 minutes, until an even colour is acquired.
Note: Adhesive must be mechanically mixed.
- Apply the adhesive to the back of the sheet, using the recommended 5mm x 5mm notched trowel. The adhesive should be applied approximately 15mm from the edge of the sheet (where joint strips are to be fitted), and right up to the double sided tapes.
- The working time of AltroFix W139 is approximately 40 minutes and AltroFix W639 is 30 minutes depending on the ambient temperature of the room.
- The trowel must be held so that the adhesive is applied to an even finish, and the trowel notches are replicated to the same depth over the sheet.

Health and Safety Advice

Before using this adhesive, users must refer to the SDS (Safety Data Sheet) for correct safety advice and carry out a COSHH (Control of Substances Hazardous to Health) assessment and risk assessment.

Always wear appropriate PPE (Personal Protective Equipment) and RPE (Respiratory Protective Equipment) when handling adhesives and ensure the area is adequately ventilated.

In the case of contact with eyes or skin, rinse immediately with plenty of water and seek medical advice.

Please ensure you follow the installation guidelines carefully to ensure best results.

Fitting the Altro wall sheets

Altro Whiterock (REF: W103/104, W136/137, W140/141, W160/161), WDS25 and WDS30.
Altro Fortis Titanium (REF: FT/XXX).

- After applying the adhesive, carefully remove the double sided tape 'protective film' and place into a rubbish container. Lift the sheet and install to the required location, ensuring the datum line on the sheet corresponds to the datum line on the wall.
- Once fitted to the substrate, apply pressure to the whole of the sheet face to ensure the adhesive has been transferred and will be fully bonded to the substrate (this is normally done with a hand roller or block of timber covered with a material to prevent the surface being damaged).
- Failure to ensure a good transfer of adhesive to the substrate could result in the sheet debonding.
- Ensure any adhesive residue is thoroughly cleaned off the surface of the sheet or joint trims (and other adjacent surfaces). This must be done immediately, before the adhesive sets.

Note: Altro Fortis Titanium should be installed with all of the sheets in the same orientation. There is an arrow printed on the protective foil to aid with alignment.

Fitting two part PVCu joint trims (REF: A831)

- Once the sheet is in position, the 'back' section of the two-part PVCu vertical joint strip should be fitted. This should be slid behind the leading edge of the sheet until it is approximately 3mm from the central spine.
- If a PVCu 'transition strip' is to be used to create a joint between the sheet and the sheet vinyl floor finish, the back part of the vertical strip should be cut back (by 20mm) to allow the horizontal transition strip to be fitted at the base of the sheet (at a later stage). To find the correct length of the vertical section required, use a small piece of transition strip (as a template) and fit this to the bottom of the sheet.
- When fitting the next sheet, ensure the datum lines are aligned correctly and then position the sheet on top of the back section of the PVCu joint strip, approximately 3mm from the central spine.
- A 2-3 mm gap either side of the central spine will allow the sheets adequate room to expand and contract underneath the 'front' face of the two-part (snap-on) cover trim.
- Carry out this procedure throughout the installation and then finish by installing the 'front' face of the two-part (snap-on) cover trim, cut to the appropriate length. **Note:** the 'front' face cover trims can be installed as the work proceeds, or left until all sheets have been installed.
- The 'front' face joint strip covers should initially be positioned by hand pressure. They can then be fully located by tapping with a rubber mallet or small hammer and wooden block.

Fitting single part PVCU joint trims (REF: G831)

- The process of the single part joint strip is much the same as the two-part trim except, during the preparation of the sheet a small chamfer will need to be applied to the edges of the sheet. This will enable the single part joint strip to be fitted more easily to the sheet. The joint trim has a moisture resistant gasket seal on the inner edges which could be damaged if forced onto the sheet.
- Once the first sheet has been installed, the single part joint strip is fitted onto the 'leading' edge which meets the next sheet. After the next sheet has been prepared and adhesive applied, a bead of Altro sanitary sealant should be applied alongside the joint strip prior to that subsequent sheet being installed. The joint strip must then be knocked over the second sheet edge to achieve a sealed joint detail. By applying Altro sanitary sealant to the back edge of the joint strip, it prevents the strip being moved at a later stage and the sheet edge becoming visible and open.

Thermoformed corner detail

Altro recommends, wherever possible, to use a thermoformed internal / external corner detail when installing the sheets. This is achieved by heating the sheet on a thermoformer unit and manually forming the sheet to the desired angle.

Altro wall sheets thermoformed corners

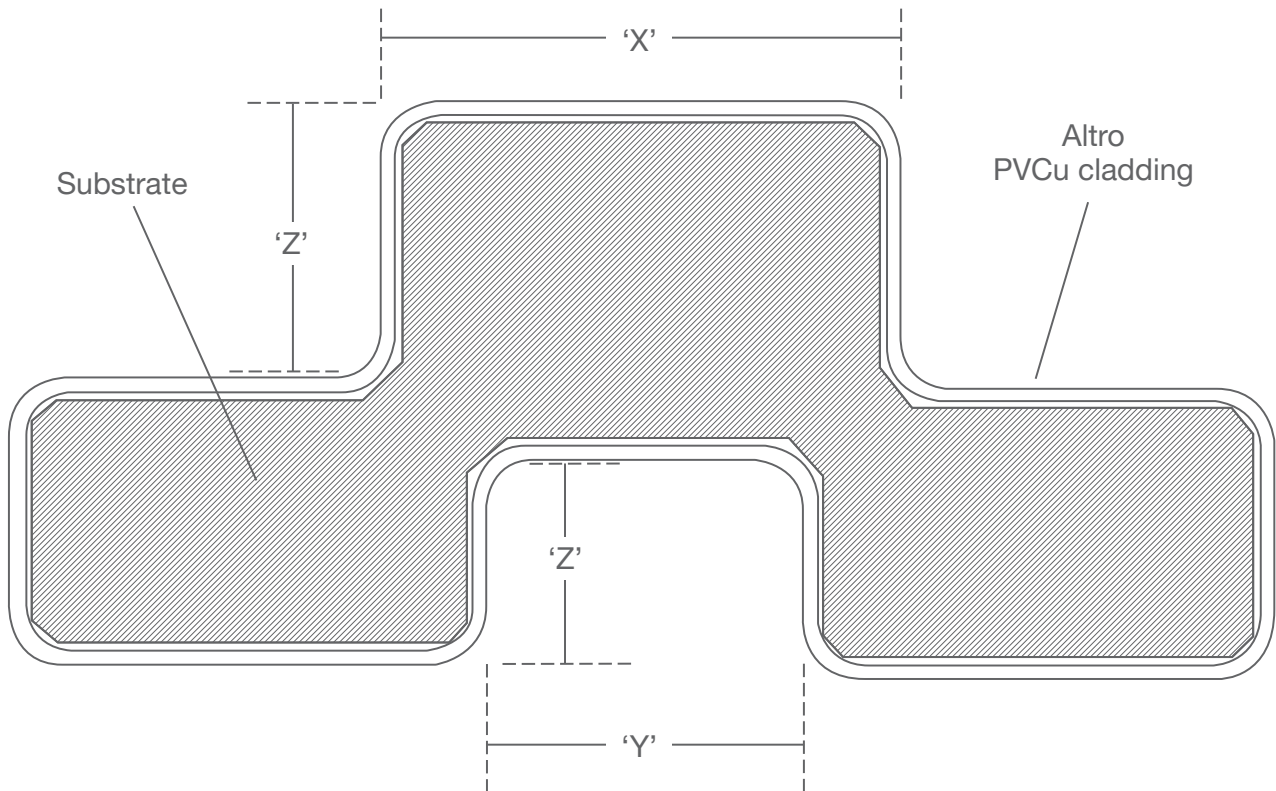

'X' - External to External corners = + 8mm

'Y' - Internal to Internal corners = -8mm

'Z' - Internal to External / or External to Internal corners - Is the same measurement as substrate

All measurements to be marked on 'face' of PVCu sheets and taken from outside of previous corner

Please ensure you follow the installation guidelines carefully to ensure best results.

Fitting Altro Fortis corner protection (REF: FT/XXX/E75x75)

Corner protectors are manufactured in coordinating colours to match the Altro Fortis Titanium range of cladding systems. When ordering colour coordinated corners, remember to include the 'part number' with the specific 'colour reference number' on your order

Example: FT/213/E75xE75 – This is a corner protector in colour Kingfisher.

- Preparation - prime the wall with the Altro W165 'tape' primer sufficiently enough to cover the area that the corner protectors are to be installed. Allow the primer to dry to provide a tacky surface.
- When the walls are ready for application, double sided tape should be applied to the back of the corner protectors down the corner length. The void in-between the tape should be filled with Altro sanitary sealant (ref. A802/A803) or AltroFix MP600 adhesive.
- Remove the protective cover from the tape and apply the corner to the substrate.
- A bead of Altro sanitary sealant should be applied to both sides of the corner profile (on the inner faces). This will prevent the panel from having a void where the tape stops short of the panel edge (see diagram).
- The front covers should initially be positioned by hand pressure. They can then be rolled to ensure adhesion, and any excess silicone tooled off.

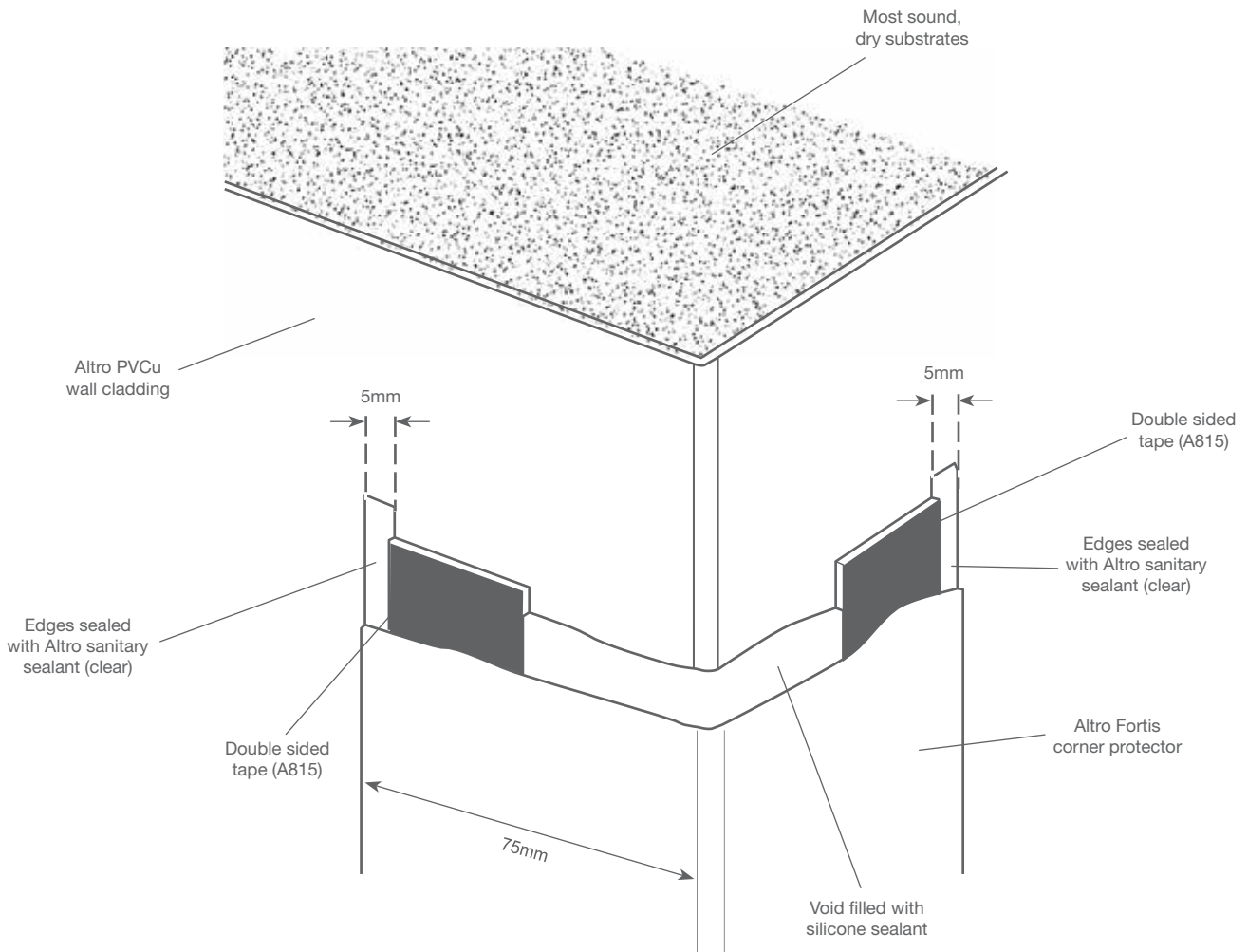

Please ensure you follow the installation guidelines carefully to ensure best results.

Joint treatment detail

If specified, or specifically recommended by the client, Altro Fortis Titanium panels can be installed with an Altro sanitary sealant joint detail.

- The panels should be installed with a 3-4 mm gap.
- Altro double sided tapes must be fitted approximately 3mm in from the vertical edge of each panel to ensure the panels meet accurately at the joint.
- Altro recommends using masking tape on the front face of the panels to prevent overspill.
- The edges of the panels must be cleaned prior to siliconging.
- Ensure sufficient silicone is pumped into the joint so that it forms up against the double side tapes on the reverse of the panel.
- Once completed, tool off the surplus to leave a neat, flush, sealed joint.
- (Remove masking tape immediately sealant is tooled off)
- In wet areas such as wet room adaptations,etc. Altro specifies the 50mm Overlap detail.

Silicone seal joint detail

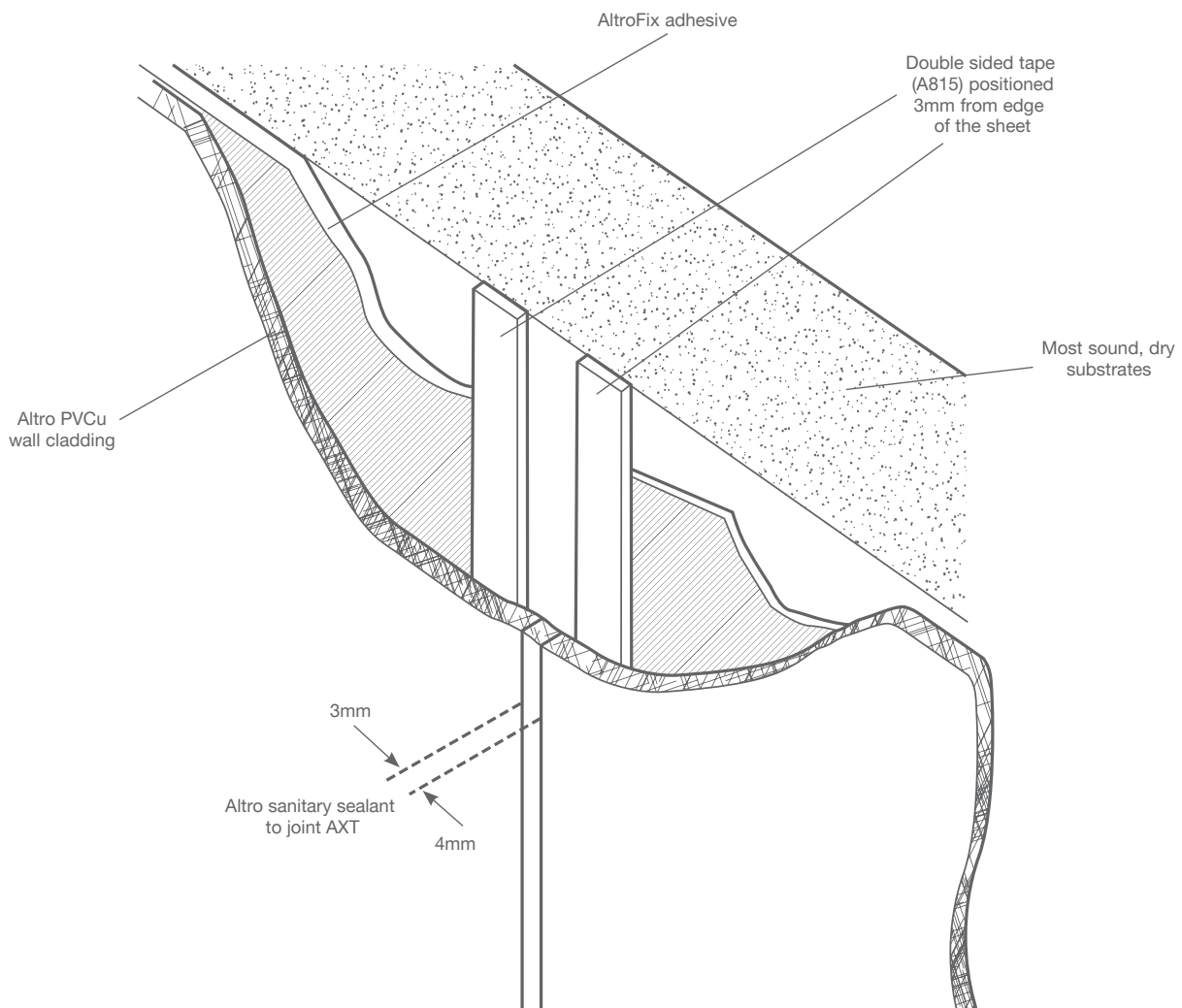

Please ensure you follow the installation guidelines carefully to ensure best results.

Welded Joints

Substrates - when installing Altro PVCu sheets with welded joints, it is imperative the substrate is to a very high standard. Surfaces should be true and level to $\pm 3\text{mm}$ over a 2m straight edge. Recommended substrates include plasterboard, plywood*, finishing plaster and most types of sand & cement render. We recommend all plastered surfaces are sealed with Unibond PVA sealer (or similar) diluted 1:10 parts water before fitting sheets.

Planning layout - when planning the layout of the sheets it is important to minimise the number of joints in the walling system. Ensure joints do not fall too close to corners. We suggest joints should not be formed any closer than 300mm from a corner. This will avoid any possible risk of mis-alignment between the joint when the next sheet is fitted.

Preparing the joint - Before installing the sheets, you must fit the white 'Foam Double Side Tape' (A915) to the substrate at the centre point where the two sheets meet. The double side tape is impregnated with a 'contact adhesive'. Therefore, all substrates must be primed before fitting the tapes. The primer is only required where the 50mm wide tapes are to be fitted.

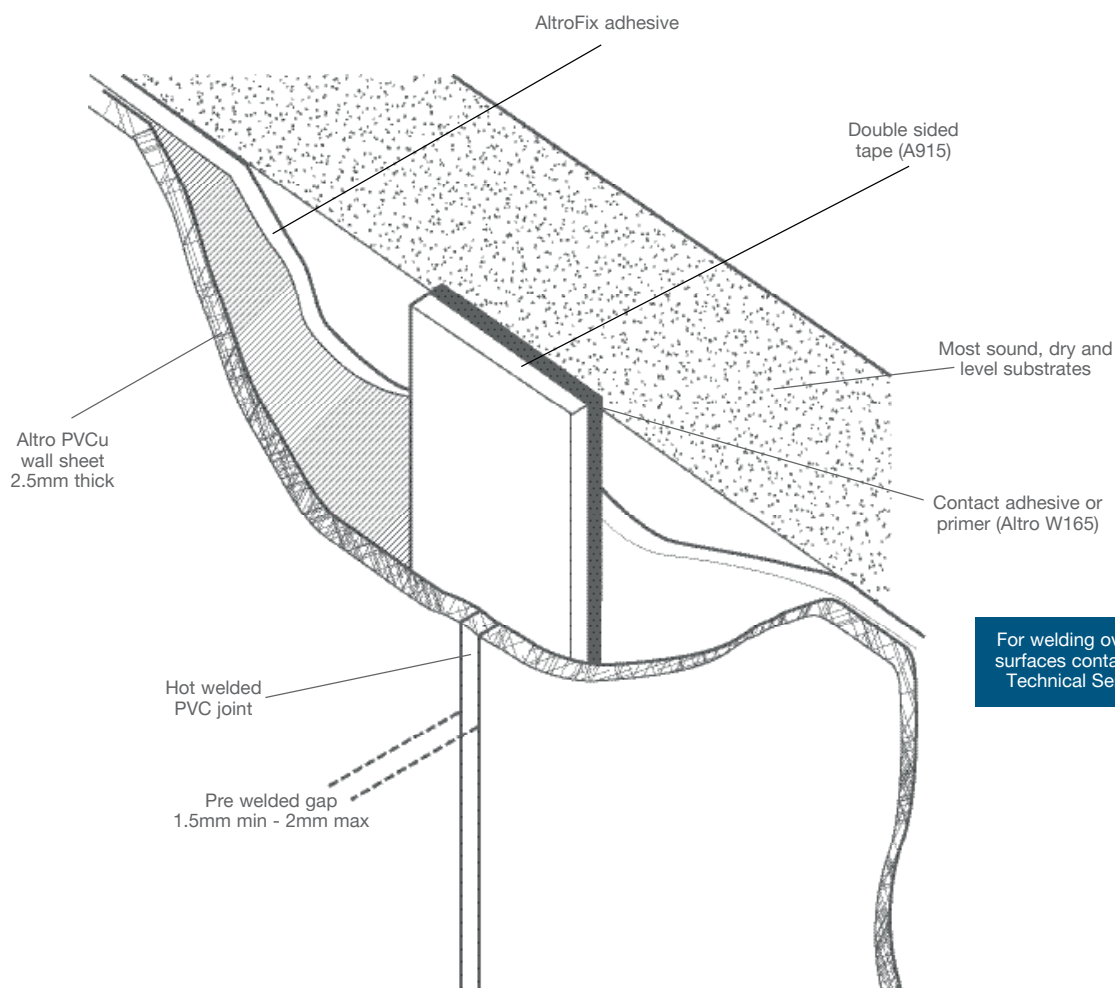

For welding over tiled surfaces contact Altro Technical Services.

Please ensure you follow the installation guidelines carefully to ensure best results.

Sheet preparation - ensure all sheet edges (where joints are to be formed) are clean, smooth, true and level.

Always inspect new sheet edges are undamaged or scored. If necessary, cut and plane to a square edge.

Check there are no 'fines' left on the edge of the sheet. These 'fines' could burn when hot welding the joint and will leave a blemish which can not be removed from the joint.

When preparing the fitting of the sheet, always ensure there is an adequate gap (2-3mm) between the sheet and any rigid abutments (ceiling, windows, doors, services etc) to allow for expansion.

These 'isolation' joints must be sealed with Altro sanitary sealant.

Application methods - after priming and fitting the Foam Double Side tapes, leave the protective top film in place (this will be removed at a later stage). Check sheets for shade variation.

Once the sheets have been prepared and dry fitted to check everything is correct, apply the adhesive to the back of the sheet in the normal way. Mark a line 25mm in from the sheet edge and apply the adhesive to this point, this ensures full coverage up to the tape applied to the substrate. Failure to apply the adhesive to meet the tape may lead to excessive sheet movement once installed.

Install the sheet ensuring the sheet is temporarily supported on timber blocks (or similar) to prevent slipping.

Check the sheet is aligned with the datum line before rolling the sheet to achieve a transfer of the adhesive to the substrate. When rolling the sheet, start in the middle and work outwards. At this stage do not roll right to the edge where double side tape is located.

Once the sheet has been rolled (almost to the edge), carefully cut down the edge of the sheet where the tape is located, to cut through the protective top film.

Carefully ease out the edge of the sheet to facilitate the removal of that half of the protective top film. Once this has been removed, press the sheets firmly onto the tape to achieve a full bond.

Finally, complete the full rolling of the sheet right up to the edge to ensure good transfer of the adhesive.

Make sure the exposed edge of the sheet is clean and free of any adhesive residue. If necessary, clean thoroughly before the adhesive cures.

Prepare the next sheet in the same way as described above. Before fitting this sheet you must fit a series of "spacer pins" against the edge of the previous sheet. This is to provide the correct 'gap spacing' between each sheet. The spacer pins should be 2mm thickness. Do not exceed 2mm thickness.

Fit the next sheet as described above, ensuring the sheet is butted tightly to the spacer pins. to ensure the joint is equal once the sheets are fitted.

Once the sheet has been rolled almost to the edge, remove the spacer pins and then remove the final part of the double side tape protective cover. Press the sheet firmly onto the foam tape and then complete the rolling of the sheet.

Check all edges are clean and free of adhesive residue.

Once the installation of the sheets is complete, you are then ready to weld the joints. On larger jobs, you can weld the sheets 'as you go'. However, we recommend welding does not take place until the adhesive has completely set up. (Usually the next day).

Hot welding - firstly, ensure your weld rod and the joint gap to be welded is clean and free of dust and contamination.

The hot welding technique used to weld Altro PVCu sheets is basically identical to that used in vinyl floor laying. The same type of tools and welding gun can be used. (See attached tools list). A Leister 5 mm round speed weld nozzle with small air slide (105.433) **MUST** be used for welding all Altro Whiterock wall designs installations - see separate welding instructions for Altro Whiterock wall designs.

The Altro 'welding rod' is also very similar to that which is used in flooring.

Whilst most floor layers use the large 'Leister' Hot welding gun, this can be slightly cumbersome and heavy in the hand when welding 3 metres up a ladder.

The preferred welding gun is the 'Leister' Hot-Jet "S" welding gun, which is smaller and more compact.

The weld rod is passed through a standard 5mm 'speed weld nozzle" which softens the weld rod and sheet edges simultaneously to fuse the materials together under heat.

The temperature of the weld gun can be regulated and the settings depend on the speed at which you travel along the sheet.

This is something each individual must practice to ascertain what suits your method of working.

In most floor laying work the typical speed would be approximately 2 metres per minute. However, this is not always practical when working vertically, so you must **practice** to gain experience of different situations.

Trimming off - this is often the part of the job which can be most difficult. Unlike flooring, you are welding a plain, smooth wall finish, which can highlight any imperfections in your work.

Whilst many fitters choose to use their 'own' pre-fabricated trimmers, at the end of the day – you need to have a trimming tool that you are confident in using and **practice extensively** with to get the live jobs right.

In our opinion, the range of trimming tools currently available to the flooring trade will achieve good results if care is taken.

After completing the welded joint you should pre-cut the joint, the Mozart trimming knife is the preferred knife of most fitters.

Pre-cutting must be done by using the 'trimming guide' and spatula to take off approximately half of the weld rod. This allows the weld rod to 'settle' and will prevent sinking into the joint once the rod has cooled.

During this process, apply a liberal amount of Altro 'Antistatic solution' sprayed on to the joint before any trimming takes place. This will reduce any friction between the cutting blade and the sheet and minimise the risk of scratching the sheet.

After pre-cutting the weld rod, allow the rod to cool down sufficiently before completing the final trimming.

Once the rod has cooled down (cold) you can commence final trimming with the spatula (or your personal trimming tool).

Take care not to scratch or damage the surface of the wall sheets while undertaking this final part of the operation... **"Practice makes perfect"**.

Welded joint instructions for Altro Whiterock wall designs

The technique used to weld Altro Whiterock wall designs is different to the one used to weld standard Altro Whiterock. Installers must read these instructions fully before commencing to weld Altro Whiterock wall designs sheets and it is strongly advised to carry out a test weld before welding the final installation.

Specialist tool - A Leister 5 mm round speed weld nozzle with small air slide (105.433) **MUST** be used for welding all Altro Whiterock wall designs installations.

Preparation - Ensure all sheet edges (where joints are to be formed) are clean, smooth, true and level. Always inspect new sheets and ensure the edges are undamaged. Damaged edges will need re-trimming. Do not bevel, profile or chamfer the edges of the wall designs sheets at seam locations. Chamfering the edges will expose the base colour of the sheet. When hot welding this could leave the exposed sheet being visible on the finished detail and make a welded joint more challenging to achieve an aesthetically pleasing seam. Check there is no debris left on the edges of the sheet. Any debris could burn when hot welding the joint and will leave a blemish which cannot be removed. When fitting the sheet, always ensure there is an adequate gap (2 mm) between the sheet and any rigid abutments (ceiling, windows, doors, services etc.) to allow for expansion. Clean both the seam area and the weldrod prior to welding.

Heat Welding - Ensure the welding equipment is clean especially the nozzle which may contain debris and carbon build up. The use of a wire brush and pipe cleaners will maintain the nozzle. **A Leister 5 mm round speed weld nozzle with small air slide** (105.433) must be used for welding all Altro Whiterock wall designs installations. The speed required to weld Altro Whiterock wall designs may be different compared to a standard Altro Whiterock sheet due to the foil used which gives the design. As a result it is essential that the correct welding speed is achieved on practice sections using off-cuts of the sheet prior to attempting an initial live weld. This will allow the installer to gauge the correct speed and heat of the welding gun to ensure acceptable weldrod adhesion and help eliminate any potential burning of the sheet. Each site will require new settings for the weld gun which depend on site electrical supply. Check for proper fusion of the weld by trying to roll the bead left to right with your finger after it has been welded. Pulling on the end of the weldrod will be a good indicator that you have successfully fused to the sheets. The temperature of the weld gun can be regulated, and the settings depend on the speed at which the gun is pulled along the sheet. This is something each individual must practice to ascertain what speed best suits their method of working. Care must be taken not to scorch the sheets, as this will be extremely difficult to repair.

Trimming off excess weldrod - When trimming the weldrod two passes are key to the process to ensure a flat weld. Choice of tools to trim the weld are installer lead, but care must be taken all chosen tools are free from rust and are smooth. Failure to follow these guidelines could result in surface defects alongside the joint. The first pass should be done while the weldrod is warm. Spray a soapy water solution or Altro anti-static solution to the sheet along the weld to help lubricate the trimming knife, blade and sledge, if using the Mozart trimming tool leave a final cut thickness of 0.5 - 0.7 mm. Once the rod has cooled down, final trimming can commence with a trimming knife and soapy water. Rubbing the trimming blades with candle wax can help to prevent scratching of the sheet surface.

Please ensure you follow the installation guidelines carefully to ensure best results.

Trimming off Installation tools and equipment for welded Altro PVCu wall sheets



**Leister Hot-Jet - "S"
110 V. Welding Gun**

Light and compact welding gun for walls and other detailed welding work.



**Rapid Nozzle
Ø 5mm**



**Super Rapid Nozzle
Ø 5mm**

For welding PVCu wall PVCu wall sheets. The hot air outflow is very tight and directed into the groove.

Mozart knife



Used for trimming of cold weld.

Trimming Guide



Used with the quarter moon knife for pre-trimming of the weld rod.

Quarter Moon Knife



Used for flush trimming of the cold weld rod.

Pajarito No. 401 Scriber



For exact scribing of one sheet edge to the next sheet.

FlexiJoint

Substrates - when installing Altro sheets with the PVC FlexiJoint profile, it is imperative the substrate is to a very good standard.

Surfaces should be true and level to + or – 3mm over a 2.00m straight edge.

Recommended substrates include plasterboard, plywood, finishing plaster and most types of steel trowelled sand and cement render.

We recommend all plastered surfaces are sealed with Unibond PVA sealer (or similar) diluted 1:10 parts water before fitting sheets and left to dry before installation process.

Planning layout - when planning the layout of the sheets it is important to minimise the number of joints in the walling system. Ensure joints do not fall too close to corners. We suggest joints should not be formed any closer than 300mm from a corner. This will avoid any possible risk of mis-alignment between the joint when the next sheets are fitted.

Preparing the joint - before installing the sheets, plan out where the joints will fall in the installation operation. Mark a vertical line on the substrate to indicate the centre of the joint. You must then prime the substrate either side of the vertical line with Altro W165 primer, using a small paint brush.

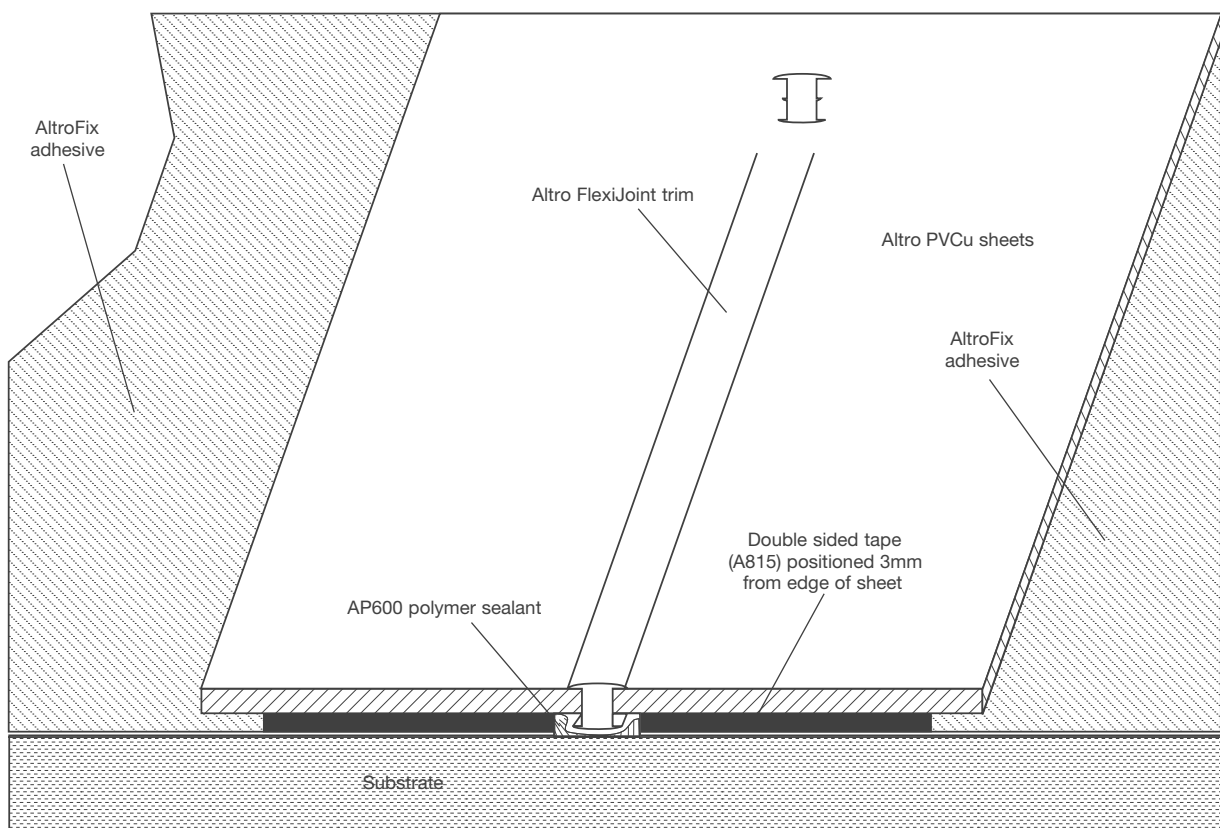

Please ensure you follow the installation guidelines carefully to ensure best results.

Sheet preparation - ensure all sheet edges (where joints are to be formed) are clean, smooth, true and square.

Always inspect new sheet edges to see they are not damaged or scored. If necessary, cut and plane to a clean square edge.

Check there are no 'fines' left on the edge of the sheet.

Altro PVCu sheets can also be cut with a circular saw (with fine tooth cutting blade), or a router (with a straight edge router bit suitable for plastics and laminates).

When preparing the fitting of the sheet, always ensure there is an adequate gap (2-3mm) between the sheet and any rigid abutments, (ceiling, windows, doors, services etc) to allow for expansion.

The edges of the sheets must be chamfered to the front and back this will allow the FlexiJoint to be inserted into the produced gap, failure to manufacture the chamfered edges could prevent the FlexiJoint being inserted smoothly.

These 'isolation' joints must be sealed with Altro sanitary sealant after completing the installation.

Once the sheet has been prepared for fitting, apply Altro double sided tapes (A815) to the back of the sheet approximately 3mm in from each edge which forms the joint for the PVC profile.

Adhesives - Altro recommends AltroFix W139 adhesive for all FlexiJoint installations.

Note: AltroFix W157 acrylic adhesive can also be used; however, this must be applied with a 5mm x 5mm square notch trowel, (increasing consumption).

Application methods - once the first sheet has been prepared and dry fitted to check everything is correct, fix the double side tapes (A815) and leave the protective top covers in place, (these will be removed later).

Apply AltroFix W139 adhesive to the back of the sheet in the normal way. Trowel the adhesive up to the edge of the double side tapes.

Install the first sheet in the normal way.

Check the sheet is aligned with the datum line before rolling the sheet to achieve a transfer of the adhesive to the substrate. Whilst the sheet is held in situ carefully ease the sheet edge away and remove cover tape, once complete remove other tape edge. Roll the sheet again to ensure adhesive transfer.

When rolling the sheet, start in the middle and work outwards.

Prepare the next sheet exactly the same as before. Dry fit this sheet to check the joint between both sheets is true and parallel. Once this check has been completed, temporarily fix three metal spacer bars (available from Altro Walls) tight against the leading edge of the previous sheet – (position at the top, middle and bottom). Altro ‘spacer bars’ are manufactured with the precise measurement to form a 3.4mm gap between the sheets.

Apply the double sided tapes and adhesive as previously described. Leave the protective cover on the strip of double sided tape which fits against the metal spacer bars, (it will be removed later). This will allow for easier fitting and manoeuvrability when butting up tight to the metal spacer bars.

Install the sheet in the normal way, ensuring the edge is fitted against each of the metal spacer bars.

Once the sheet has been fully rolled, remove the metal spacer bars. Carefully ease out the edge of the sheet to facilitate the removal of the protective cover from the back of the double sided tape. When this has been removed, press the sheet firmly back onto the substrate to achieve a full bond.

Finally, complete full rolling of the sheet right up to the edge to ensure good transfer of the adhesive.

Make sure the exposed edges of the sheet are clean and free of any adhesive residue.

Repeat this process for all subsequent sheets.

Note: Altro Walls recommends the FlexiJoint profile is inserted and fitted to the joint as work progresses.

(This will avoid any risk of the joint closing up as the adhesive cures).

Installing the FlexiJoint PVC profile - prior to fitting the Altro FlexiJoint PVC profile, clean and prime the joint. Apply a uniform bead (2mm max: thickness) of Altro AP600 polymer sealant to the substrate in between the joint gap.

Caution: Do not overfill this joint with AltroFix MP600 sealant, as this will prevent the FlexiJoint profile from seating correctly into the gap.

Cut a suitable length of the FlexiJoint profile (allow for trimming off) and then press firmly into the joint gap.

Once the profile has been fully fitted to the joint, roll the joint thoroughly with a small hand roller, (wooden wallpaper seam rollers are ideal for this task).

Finally, trim off the surplus as required.

Door heads, window heads and sill sections - door heads, window heads and sill sections need to be carefully scribed and cut to adjacent sheets to ensure a gap of 3.4mm is maintained for the FlexiJoint profile.

Floor to wall joint detail - the Altro FlexiJoint profile can be used in conjunction with all current types of Altro PVCu transition trims.

The most aesthetically pleasing method, (where appropriate), is to opt for the standard 50mm 'overlap' detail, which has the Altro PVCu sheet fitted over the top of the self-covered PVC floor finish.

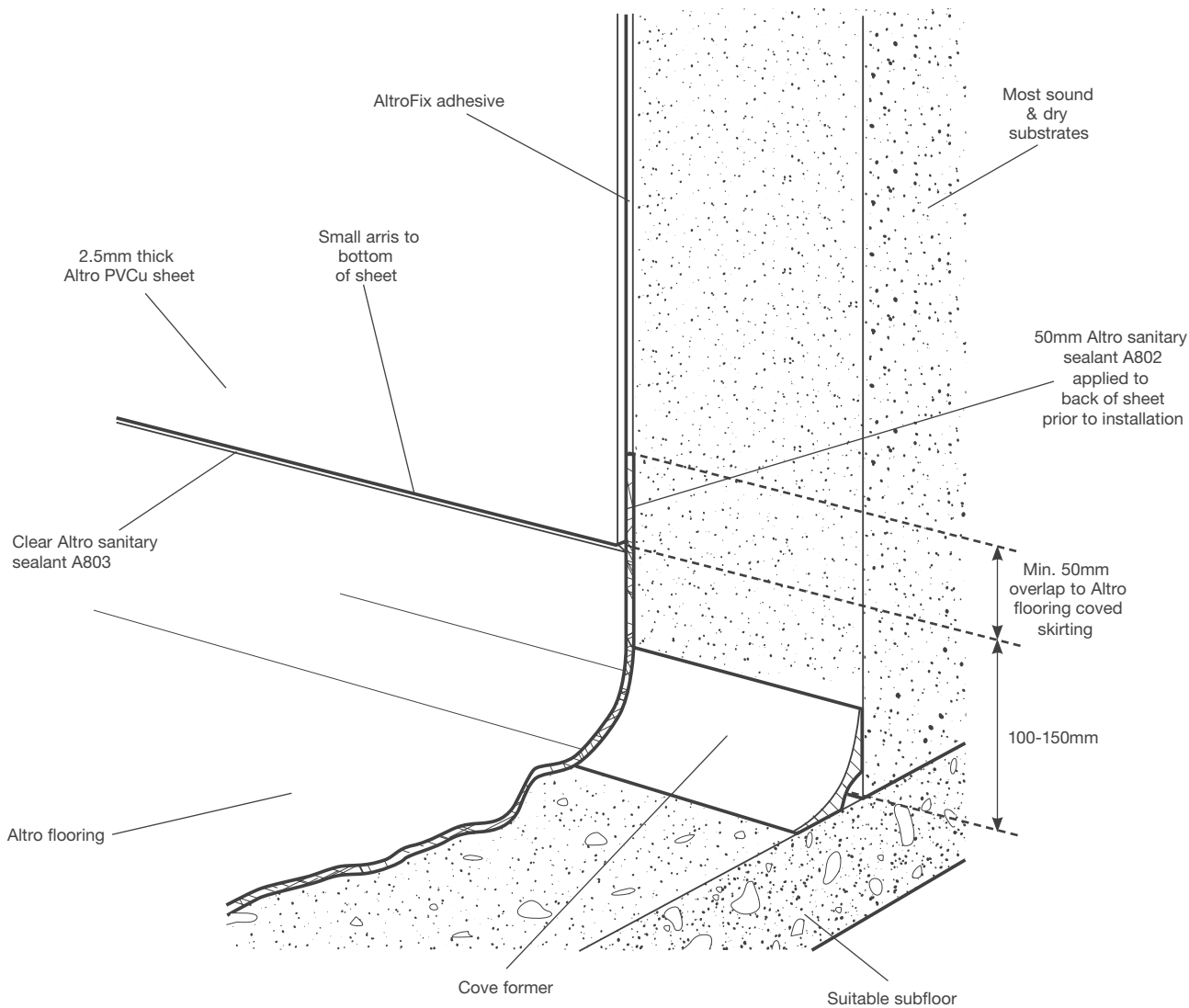

Please ensure you follow the installation guidelines carefully to ensure best results.

Fitting two-part internal / external corners (REF: F837 / F836)

Internal and external two-part corner sections are manufactured in coordinating colours to match the range of Altro walling systems. When ordering colour coordinated corners, remember to include the 'part number' with the specific 'colour reference number' on your order. F837 / F836 only refer to 'White' corner sections. For all other colours, add a suffix to the specific part number with the correct 'colour reference number'.

Example: F837/25/41 – This is an Internal corner section, 2.5m length, in colour Linen.

- Preparation - prime the wall corners with the Altro W165 'tape' primer sufficiently enough to cover the area that the corners are to be installed. This should be done at the same time as the priming out for the double sided tape, allowing primer to dry to provide a tacky surface.
- When the walls are ready for application, double sided tape should be applied to the back of the PVCu corners in four strips of approximately 150mm long down the corner length. Remove the protective cover from the tape and apply the corner to the substrate.
- If a PVCu 'transition strip' is to be fitted (at a later stage) to the bottom of the Altro PVCu sheet (where wall sheets meet the sheet vinyl floor skirting), the corner profile 'back section' must be fitted accordingly.
- Prior to the Altro PVCu sheet being installed, a bead of Altro sanitary sealant should be applied to both sides of the corner profile (on the inner faces). This will prevent the sheet from having a void where the adhesive stops short of the sheet edge.
- When fitting the Altro PVCu sheet on to the corner profile 'back section', ensure the sheets are positioned approximately 5mm short of the central spine (to allow for expansion and contraction).
- After the sheets have been fitted, the front covers of the two-part (snap-on) corner profiles can be installed.
- The front covers should initially be positioned by hand pressure. They can then be fully located by tapping with a rubber mallet. Use a small clean, smooth section of softwood timber and place over the cover before tapping with the rubber mallet.

Fitting the PVCu transition joint strip (REF: A832)

- The PVCu transition strip is fitted at the bottom of the Altro wall sheet to provide a suitable detail for the 'sheet to sheet vinyl floor' skirting detail. As described previously, the vertical joint strips must be cut accordingly to allow the PVCu transition strip to fit properly.
- Prior to fixing the transition strip to the base of the sheet, a bead of Altro sanitary sealant should be applied to the substrate (just below the sheet). When the 'back' section of the two-part PVCu transition strip is installed it beds into the sealant and maintains a tight hold during installation of the floor.

Altro wall sheet to vinyl sheet flooring cove skirting detail

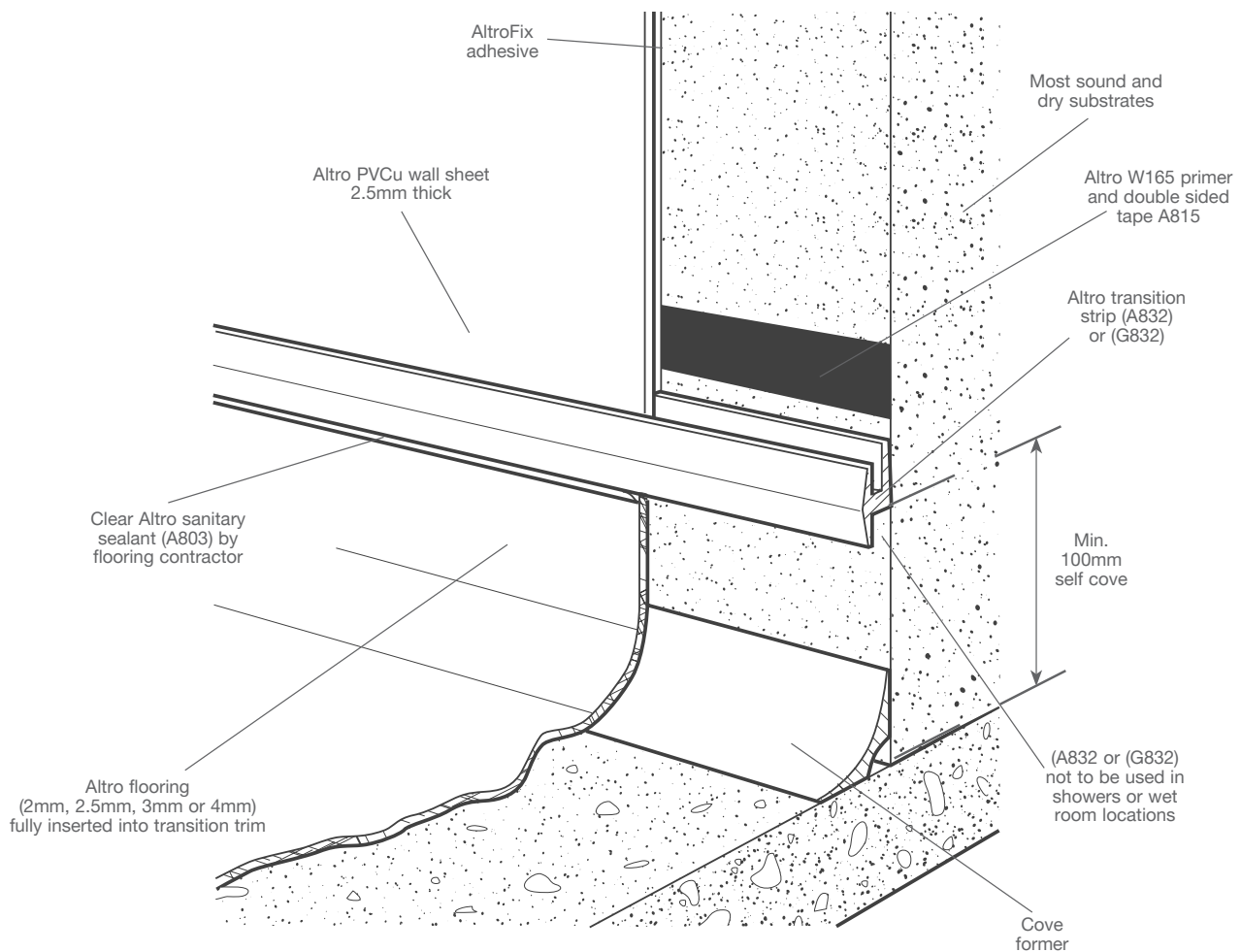

- Carry out this procedure throughout the area and then finish by installing the front cover section of the two-part (snap-on) joint strip.
- When forming the front cover around internal and external corners, the back of the trim should be carefully undercut (along the spine) to allow the trim to bend around the angles.
- The front joint strip covers should initially be positioned by hand pressure. They can then be fully located by tapping with a rubber mallet or small hammer with a block of wood.
- The front transition strip joint covers must be 'run' continuously around the perimeter of the room, including around internal and external angles. DO NOT mitre or butt into corners. The cover trim should meet up accurately with the front covers of the vertical joint strips and the internal / external corner profiles.

Please ensure you follow the installation guidelines carefully to ensure best results.

Fitting the PVCu start & edge joint strip (REF: A833)

Altro A833 is a two-part (snap-on) PVCu start and edge trim, which is generally used to close any exposed edges (i.e. top or side edges) of the Altro PVCu sheet. This is usually fitted when the sheet is installed lower than the ceiling line, or when the sheet terminates along a wall before reaching a corner or abutment.

- Prior to fixing the start & edge trim to the exposed edge of the sheet, a bead of Altro sanitary sealant should be applied to the substrate (adjacent to the sheet). When the 'back' section of the two-part PVCu start & edge trim is installed it beds into the sealant and maintains a tight hold to the substrate.

Start and edge and cut tile transition detail

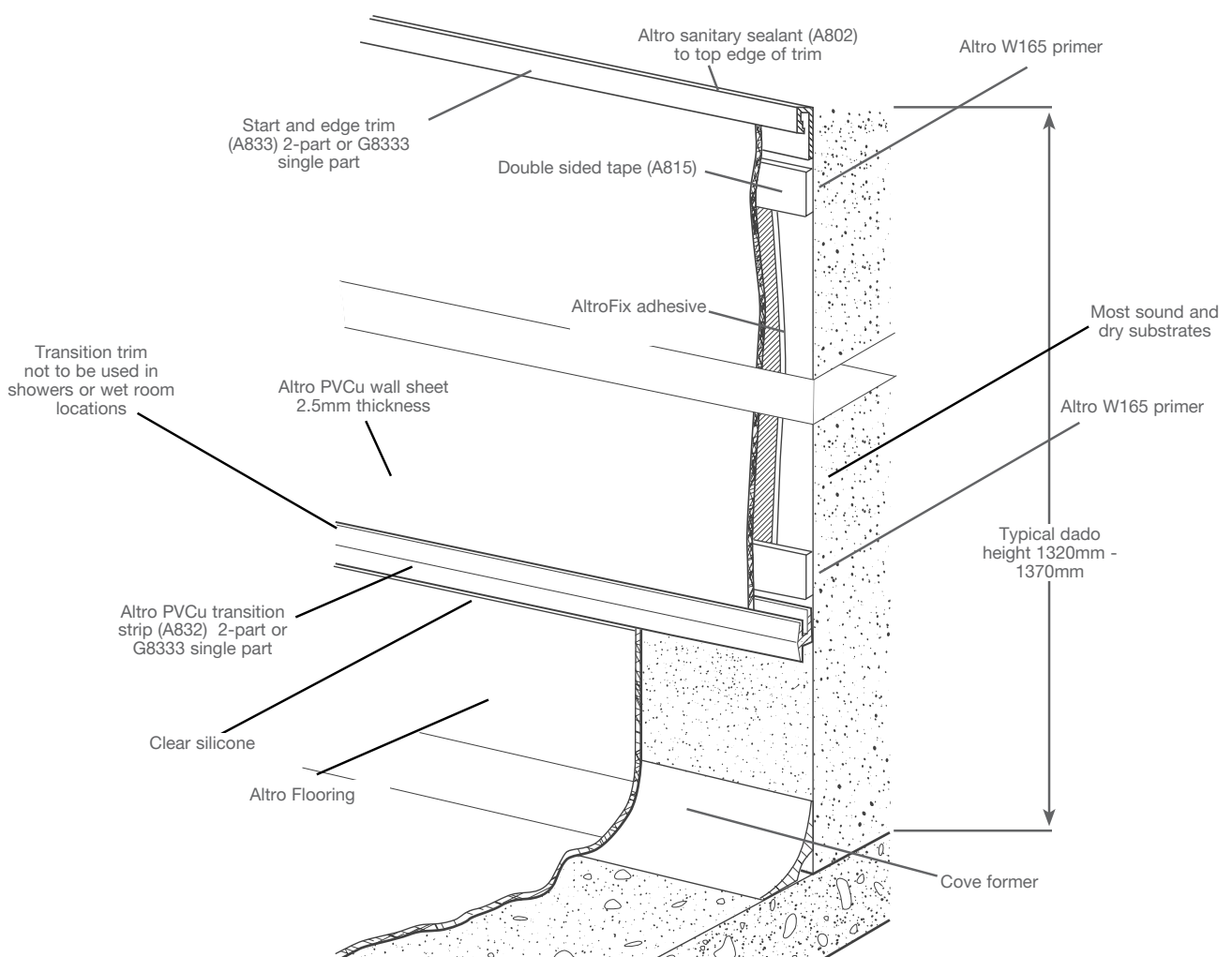

- Continue this procedure as necessary throughout the area and then finish by installing the front cover section of the two-part (snap-on) joint strip.
- The front cover strip should initially be positioned by hand pressure, and then be fully located by tapping with a rubber mallet or small hammer and block of wood.

Please ensure you follow the installation guidelines carefully to ensure best results.

Other joint treatment detail

If specified, or specifically recommended by the client, Altro wall sheets can be installed with a silicone joint detail.

- The sheets should be installed with a 3-4 mm gap.
- Altro double sided tapes must be fitted approximately 3mm in from the vertical edge of each sheet to ensure the sheets meet accurately at the joint.
- Altro recommends using masking tape on the front face of the sheets to prevent overspill.
- The edges of the sheets must be cleaned prior to siliconging.
- Ensure sufficient silicone is pumped into the joint so that it forms up against the double side tapes on the reverse of the sheet.
- Once completed, tool off the surplus to leave a neat, flush, sealed joint.
(Remove masking tape immediately sealant is tooled off)
- In wet areas such as wet room adaptations, etc. Altro specifies the 50mm Overlap detail.

The Overlap Detail

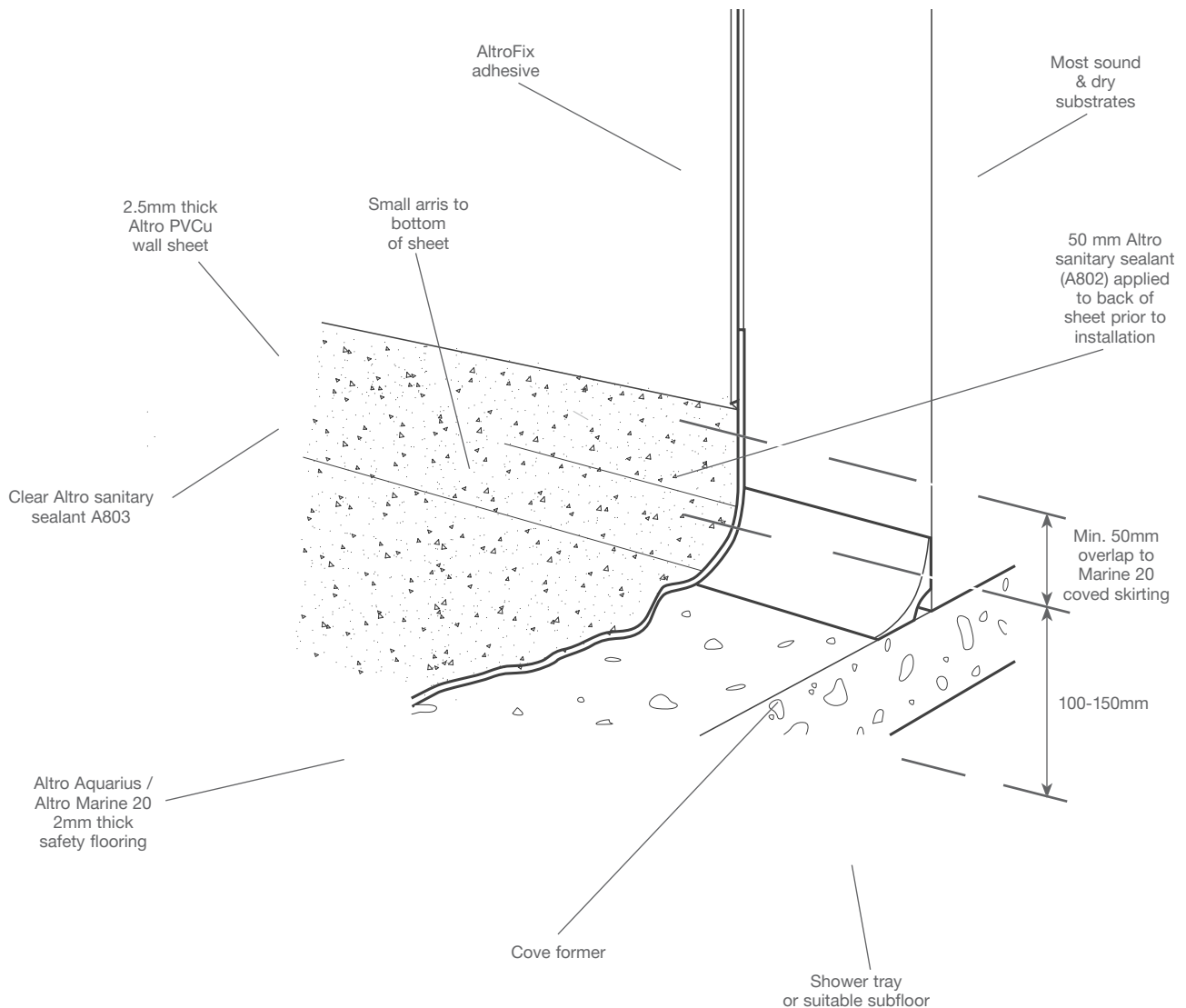

Please ensure you follow the installation guidelines carefully to ensure best results.

The Hidden Transition trim allows the Altro wall sheet installation first and the flooring to be fitted at a later stage.

The Trim is situated behind the Altro wall sheet (see diagram WHTT2 and WHTT3) enabling the Altro flooring to run up behind the Altro wall sheet and create the overlap detail, another advantage is it enables easier removal and replacement of the flooring from behind the sheet.

WHTT2

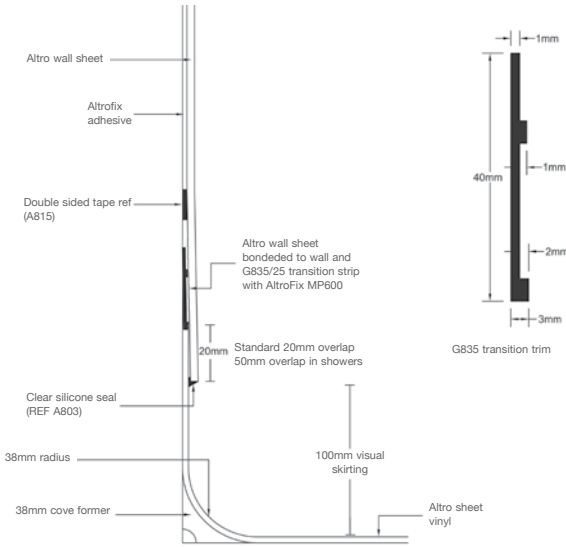

WHTT3

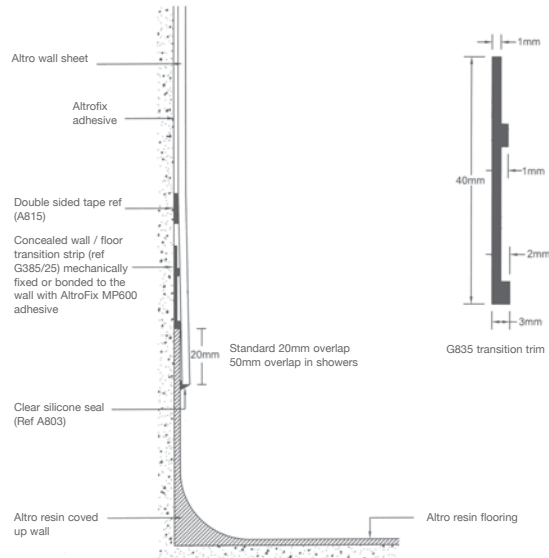

WHTT4

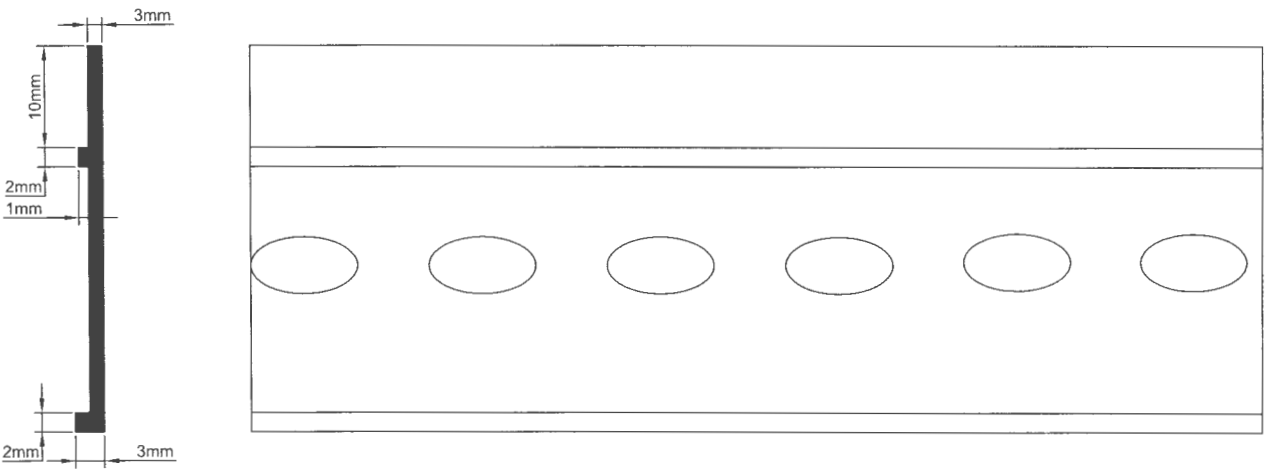

The hidden transition strip has been designed to maintain the overlap detail when replacing flooring without the need to replace the sheet, for installation guidance contact the Altro technical team on 01462 707600.

Fitting and sealing up to abutments

Altro wall sheets should be fitted to within 3mm of rigid abutments such as window frames, door frames, architraves, ceilings, quarry tile skirtings etc. Thus ensuring a 2-3mm gap at these points.

This will allow for expansion and contraction to take place.

Prior to sealing the joint, clean the sheet and adjacent surfaces.

All 'isolation' joints must be sealed with colour coordinated Altro sanitary sealant.

Detail Altro wall sheets to abutments eg. architrave

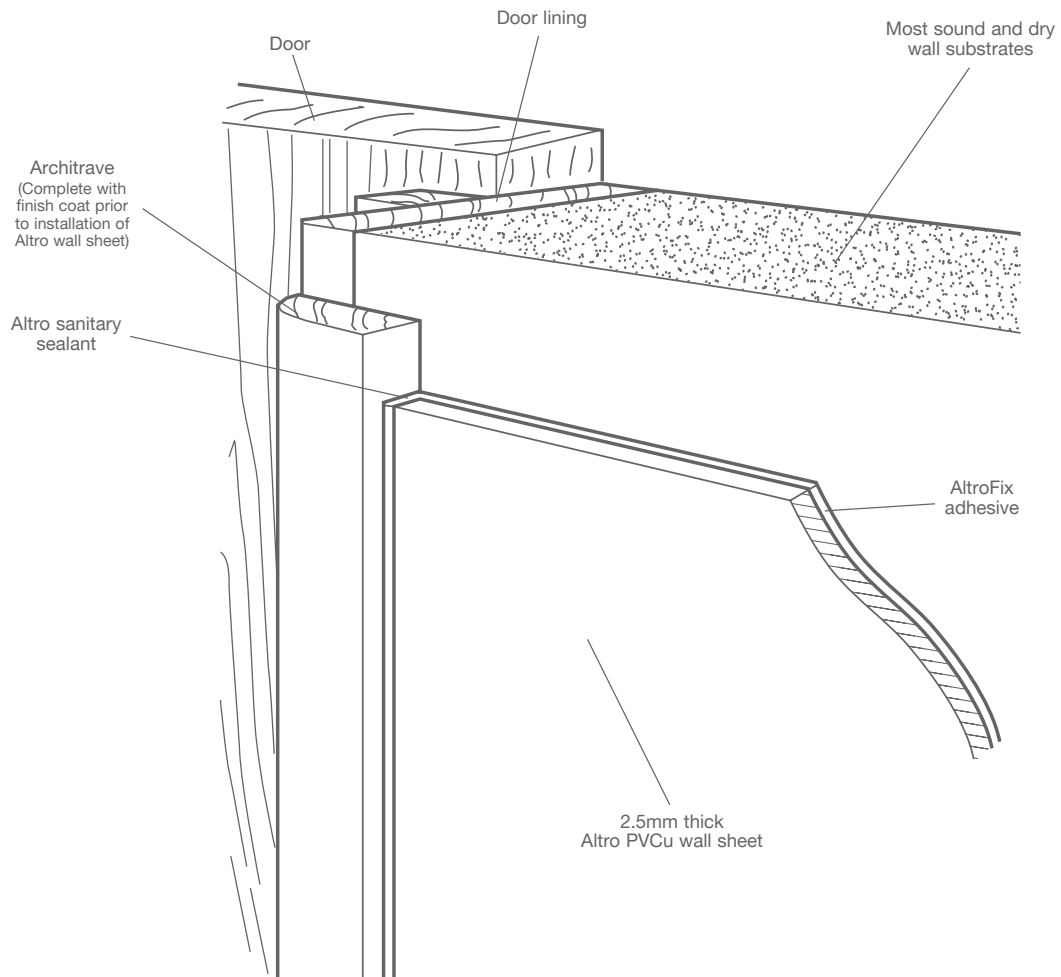

Please ensure you follow the installation guidelines carefully to ensure best results.

Completion

Once all sheets and joint strips are installed and silicone has been completed, remove the protective film and clean all surfaces down with Altro antistatic solution (A809). This is required as the sheet may have static build up and any dust in the atmosphere will adhere to the surface of the sheet.

Cleaning

Regular cleaning using a soft cloth and suitably diluted mild detergent is all that is normally required. For heavy grease contamination use Altro 44 alkaline cleaner (or similar). For stubborn marks use a non-abrasive domestic type cream bath cleaner.

When cleaning the Altro wall sheet surface, we recommend the temperature of water does not exceed 60° Centigrade.

If cleaning with hot water lance, temperatures must be regulated to a maximum of 60° Centigrade and not to be localised.

Do not use cleaning materials of an abrasive nature.

Cleaning cards are available on request.

Contact

Altro technical services department for any query regarding materials, installation or cleaning and maintenance instructions:

Tel: 01462 707600

E-mail: enquiries@altro.com

Visit the Altro website at www.altro.com for technical data sheets and technical drawings in pdf format for downloading.

April 2025

Altro Ltd, Works Road, Letchworth Garden City, Herts, England SG6 1NW.

 AltroFix, Altro Whiterock and Altro Fortis Titanium are trademarks of Altro Limited.

Content correct at time of going to print. Altro reserve the right to change any detail.